

# TRG 720 / 200T

# TRG 720 / 300T

RIDE-ON SCRUBBER DRYER

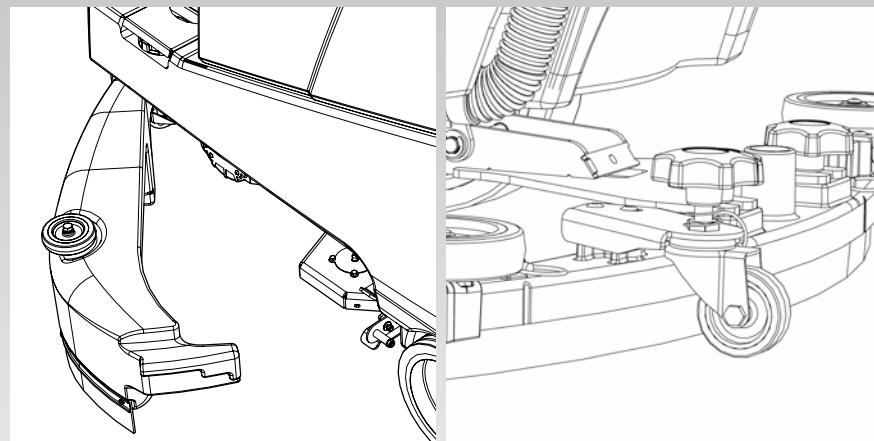
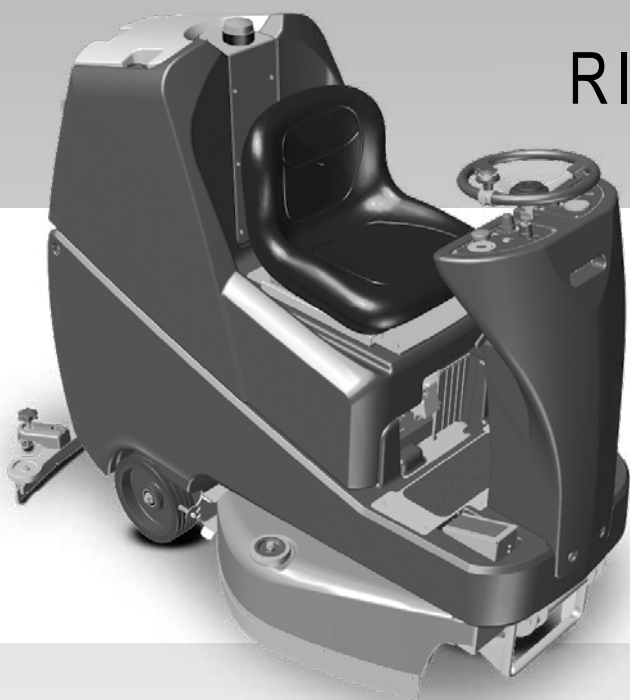

TRG 720 200T / 300T



## Original Instructions

Warning! Read instructions before using the machine



**Nu-Assist**



# TRG 720 200T / 300T

**Machine overview** .....Pages 2-3

**Control panel overview** .....Page 4

**Machine set-up guide** .....Page 5

Hose U bend clip .....Page 6

Fitting the floor tool .....Page 6

Breakaway floor tool feature.....Page 6

Fitting side pod skirts .....Page 7

Fitting the brush .....Page 7

Raise / Lower brush deckPage 8

Filling the clean water tank .....Page 8

Fill level indicator .....Page 8

Adjusting the seat .....Page 9

Setting the cleaning controls .....Page 9

Waste water tank full .....Page 10

Emergency stop button and horn .....Page 10

Maximum speed control .....Page 10

Machine in use .....Page 11

Off-aisle cleaning kit .....Page 11

**Machine cleaning** .....Pages 12-13

Fuses .....Page 13

Changing floor tool blades.....Page 14

**Free wheel and towing** .....Page 15

**Machine charging** .....Page 16

**Battery care** .....Page 17

Charging lights sequencePage 17

**Trouble shooting** .....Pages 18-19

**Specifications** .....Page 19

**Rating label / Personal protective equipment / Recycling** .....Page 20

**Safety precautions** .....Page 21 / 22

Recommended spare parts .....Page 23

Schematic diagram .....Page 23

Battery wiring .....Page 24

Warranty .....Page 25

EU Declaration document .....Page 26

Company address .....Page 28

## PLEASE READ BEFORE COMMENCING OPERATION

- Owner manual
- Battery charging lead
- 2 x Keys • 2 x 40 Amp fuses (200T) / 3 x 40 Amp fuses (300T) • 30 Amp fuse
- 20 Amp fuse
- 4 Amp fuse • 2.5 Amp fuse
- Maxi fuse-puller

1	Operator control panel
2	Brush load adjuster knob
3	Brush deck release lever
4	Brush deck foot pedal
5	Clean water tank fill point
6	Side pod and skirt
7	Brush deck
8	Side pod lever
9	Floor tool raise / lower lever
10	Seat adjustment lever
11	Separator release catches
12	Pedestrian warning light
13	2 x 40 Amp battery fuse ( 4 battery machine ) 3 x 40 Amp battery fuse ( 6 battery machine )
14	Accelerator pedal
15	Steering wheel
16	Clean water tank emptying hose
17	Vacuum hose
18	Air separator assembly
19	Waste water emptying hose
20	Floor tool vacuum hose
21	Semi parabolic floor tool
22	Fuse panel
23	Towing point
24	2.5 Amp safety fuse
25	Gel batteries
26	Charger / Charger point for chargerless Page16

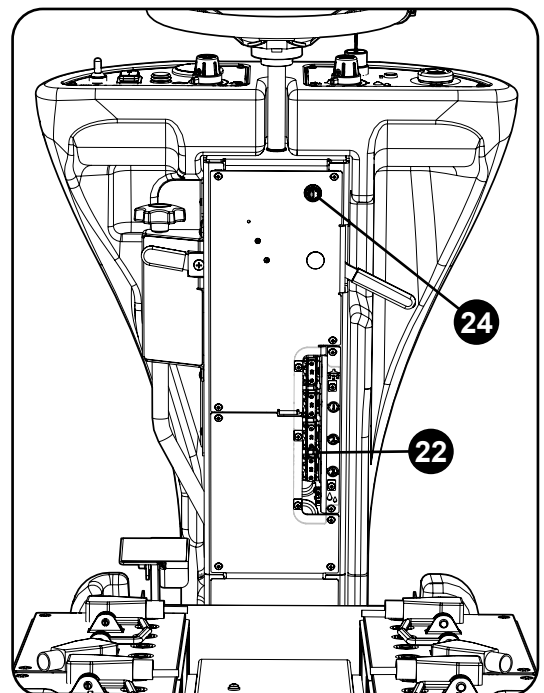
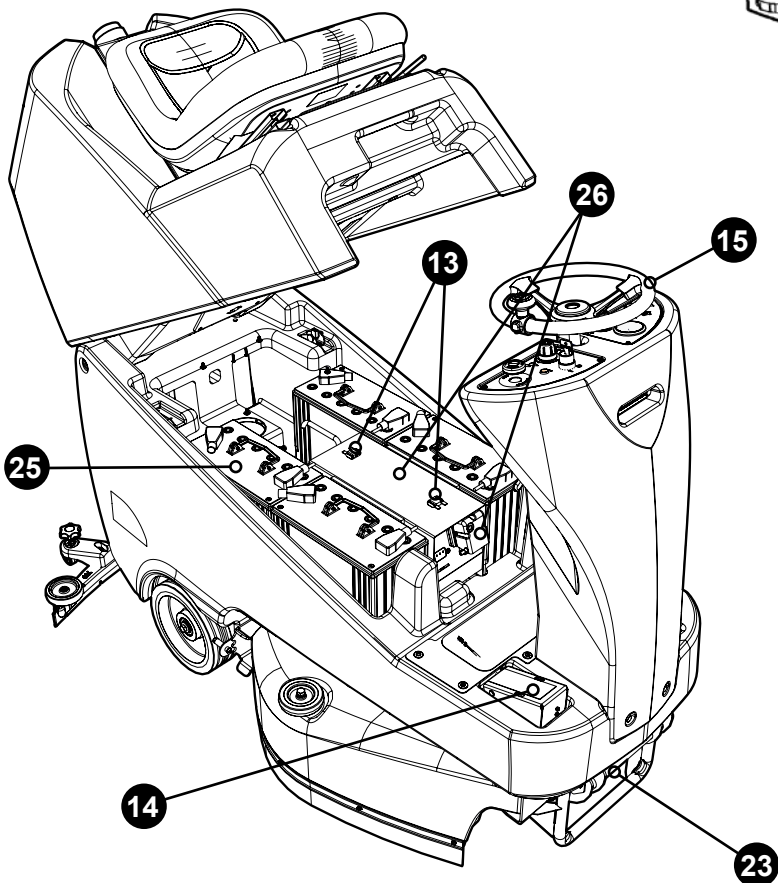
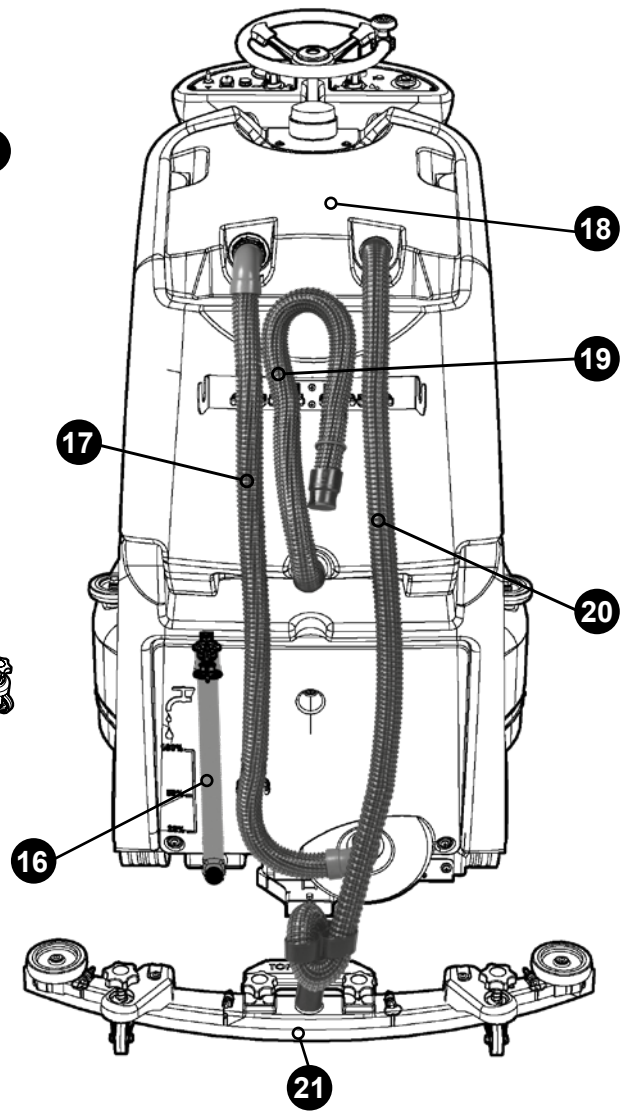
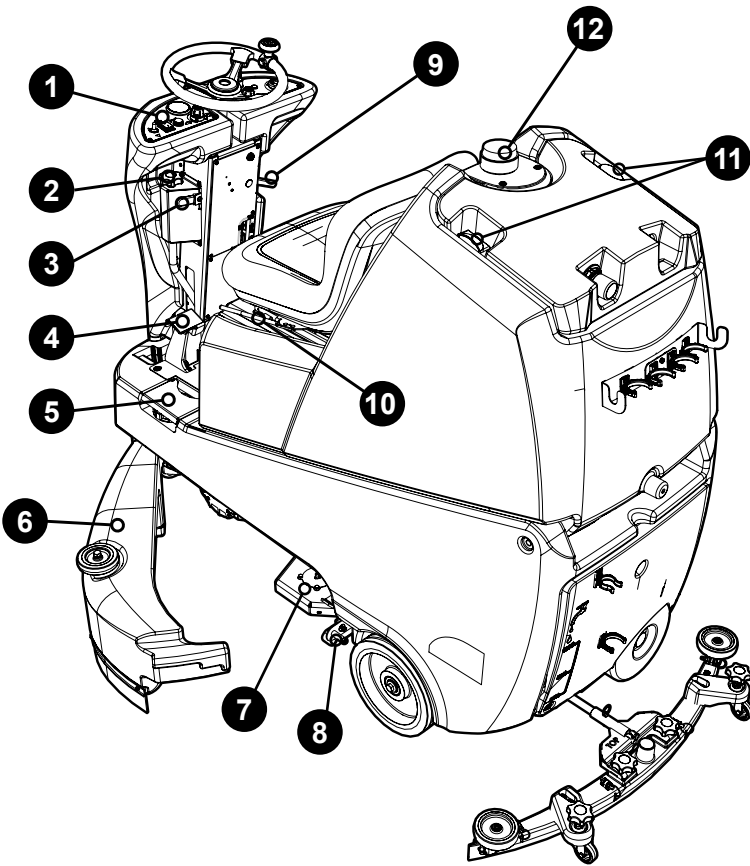

# RIDE ON SCRUBBER DRYER

# TRG 720 / 200T / 300T

## Control panel overview

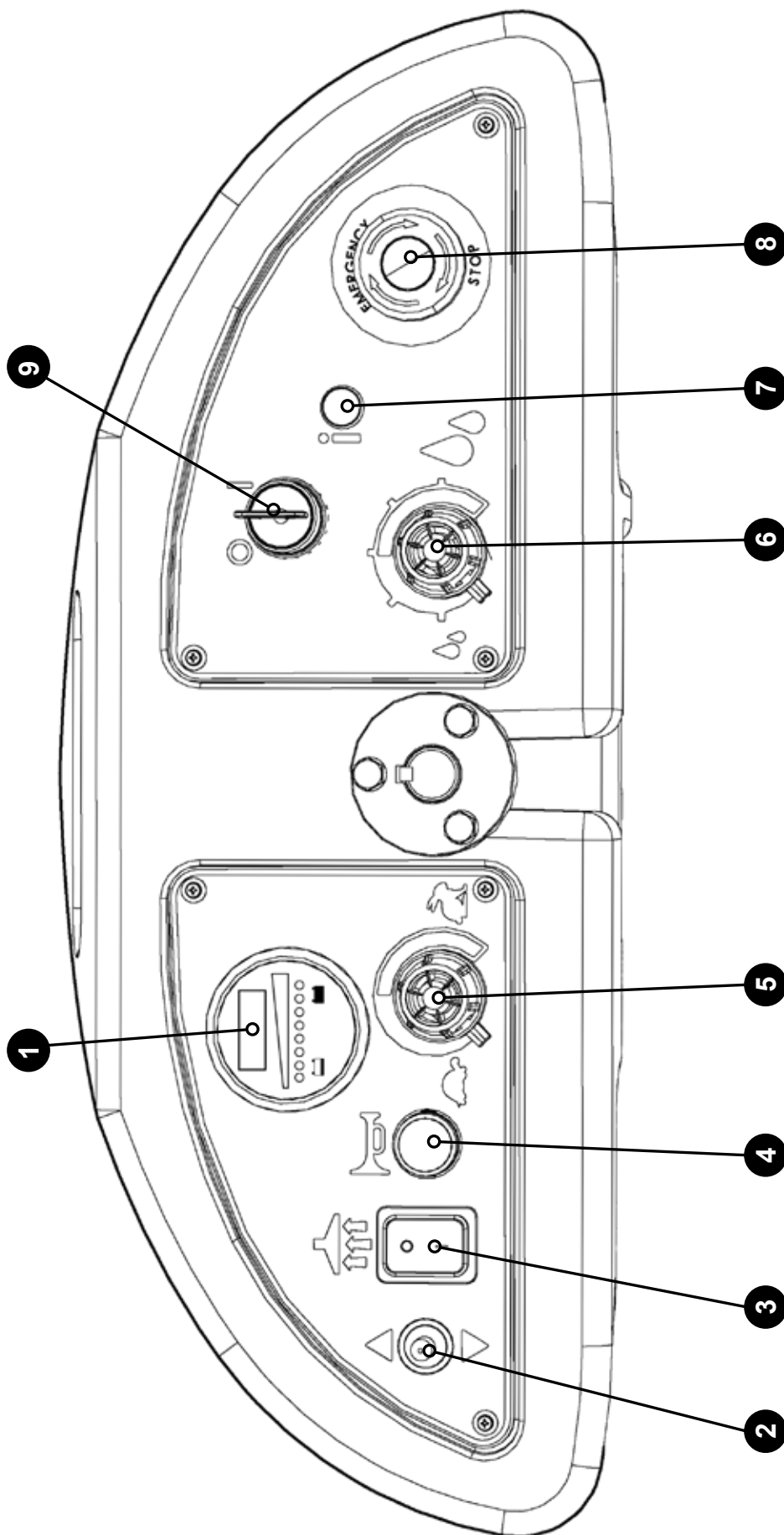

1	Hours and battery meter display	6	Water flow rate
2	Forward / Reverse switch	7	Traction LED
3	Suction On / Off switch	8	Emergency stop button
4	Horn button	9	On / Off switch
5	Maximum speed control		

*In the event of a breakdown contact  
your Numatic dealer or the  
Numatic technical  
help line +44 (0)1460 269268*



**PLEASE READ BEFORE COMMENCING ANY OPERATION AFTER THE REMOVAL OF ALL THE PACKAGING, CAREFULLY OPEN AND CHECK THE CONTENTS.**



- Owner manual
- Battery charging lead
- 2 x 40 Amp fuses (200T) / 3 x 40 Amp fuses (300T)
- 30 Amp fuse • 20 Amp fuse
- 4 Amp fuse • 2.5 Amp fuse
- Maxi fuse-puller
- 2 x Keys

Lift top tank assembly to reveal battery compartment, ensuring you use the handle grip provided.

Fit battery fuses (contained in start-up pack) into the battery fuse holder as illustrated.

Insert key into ignition located on the control panel.

*Note: Wear suitable gloves when inserting fuses.*

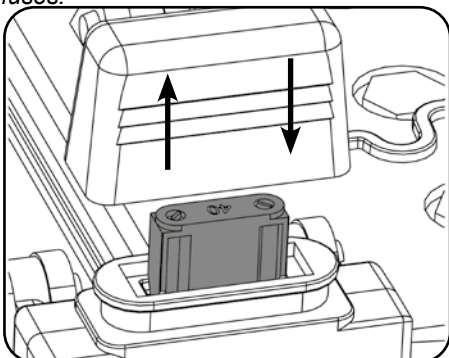
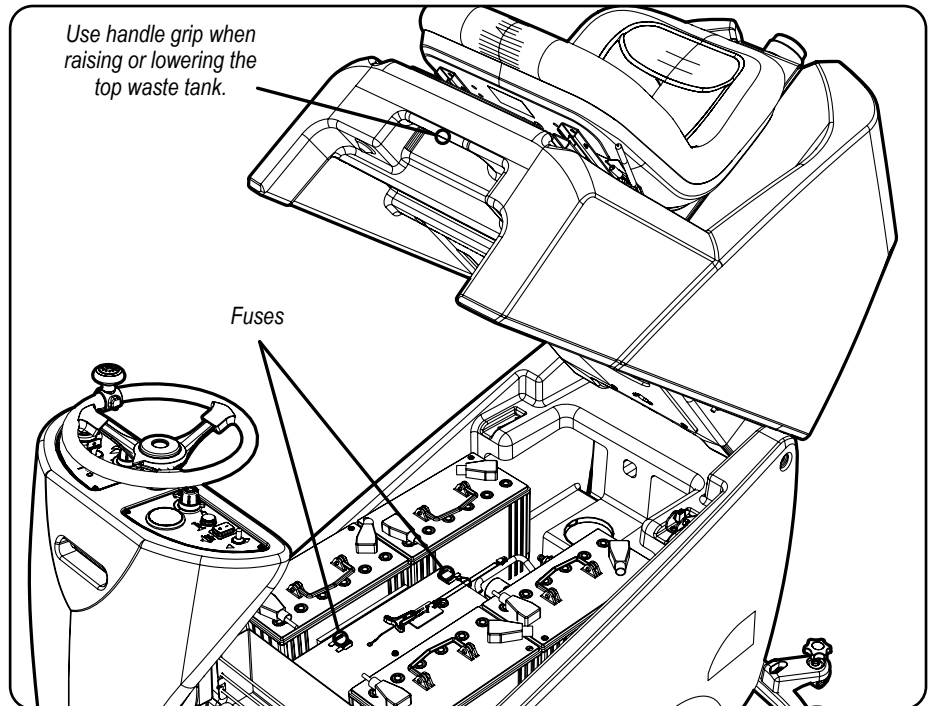

Lift fuse cover and Insert battery fuses.

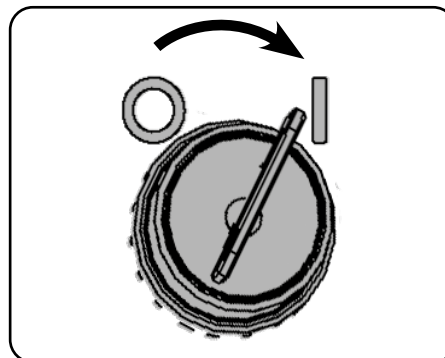

Switch on the machine. Remove the key when the appliance is not in use.

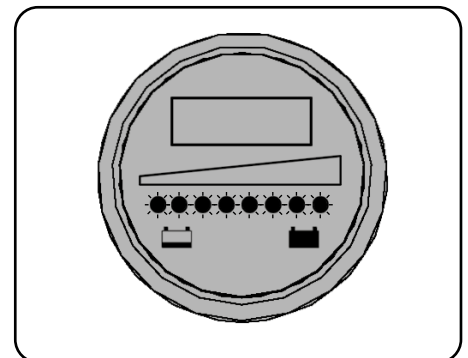

Battery display panel illuminates to show power.

*Less battery models - Numatic International Ltd recommends using MK Batteries for the TRG machines mentioned in this manual. For full battery specifications see page 24.*



*Note: DO NOT depress accelerator pedal while software initialises. The machine will not operate in reverse with the floor tool lowered. The seat is fitted with a pressure sensor that disables the machine until an operator is seated.*

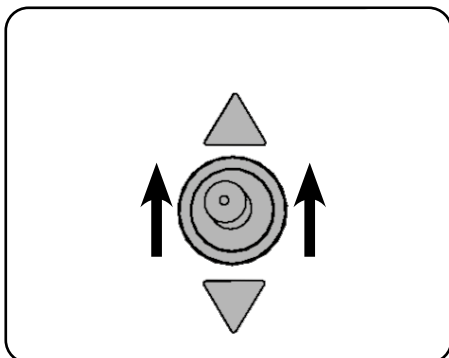

Set direction switch to forward.

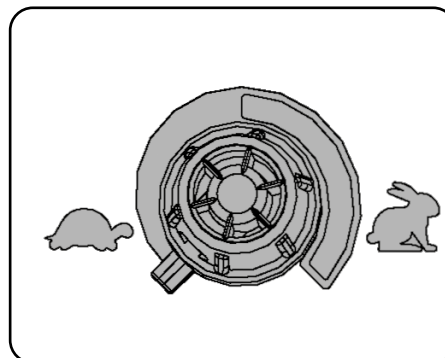

Set to slowest speed, depress accelerator and drive off the pallet using ramp provided.

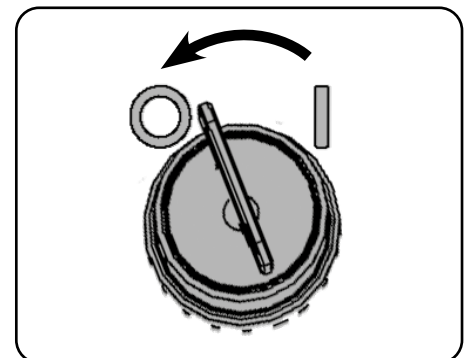

Once in a safe location switch off machine.



## Machine set-up guide

### Fitting Dump Hose

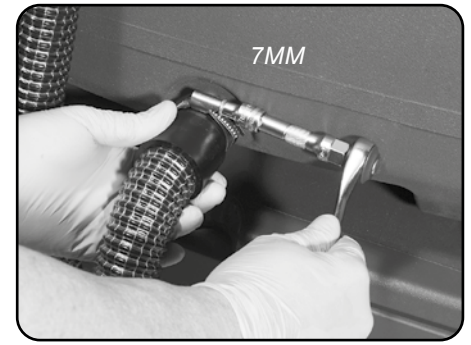

### Hose U-bend clip

The U-bend in the hose prevents water spillage when the vacuum is switched off.  
Refit vacuum hose to the floor tool when finished.

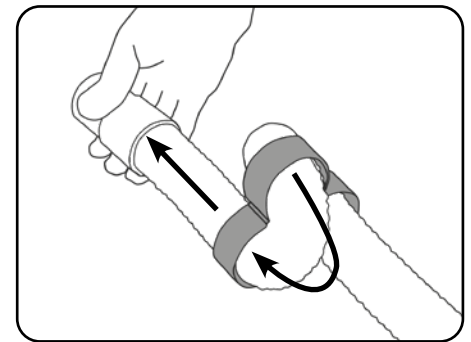
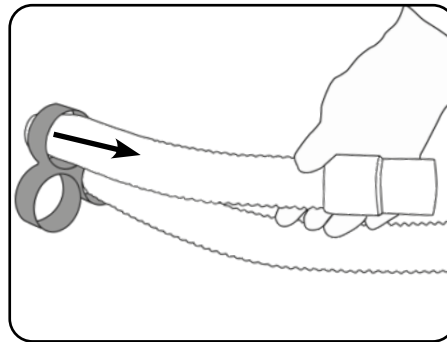
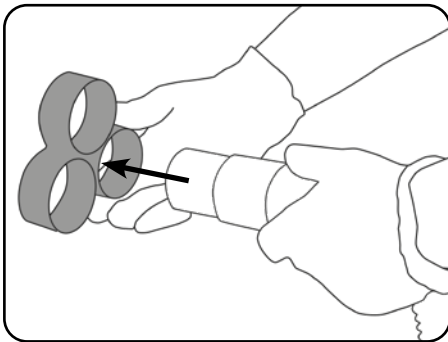

**NOTE:** DO NOT push the vacuum hose onto the floor tool with the floor tool in the raised position.

### Fitting the floor tool

**NOTE:** Raise floor tool before driving to the cleaning area.  
The machine will not operate in reverse with the floor tool lowered.

Lower the floor tool arm by moving the release lever to the upper position (Fig.1).

### Break-away floor tool

The floor tool design incorporates a safety knock-off feature, this allows it to safely disengage from its mounting should it become caught on an obstruction during forward movement.

Please ensure you do not over tighten the retaining knobs.

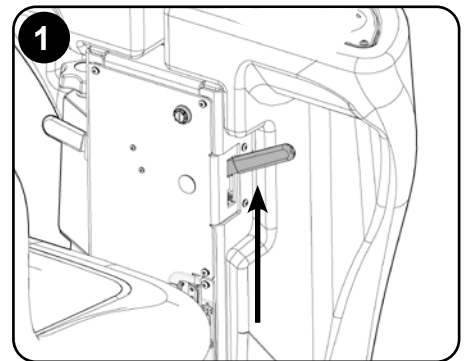

Lower the floor tool.

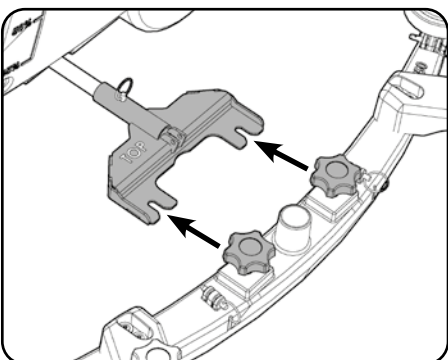

Slide floor tool onto bracket.

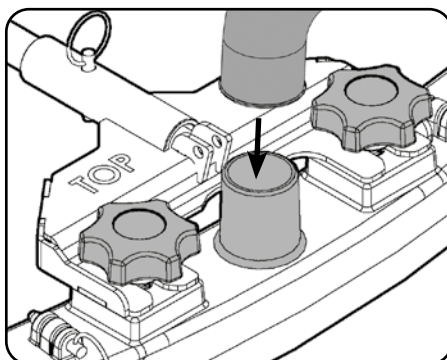

Tighten retaining knobs to finger tight and attach hose.

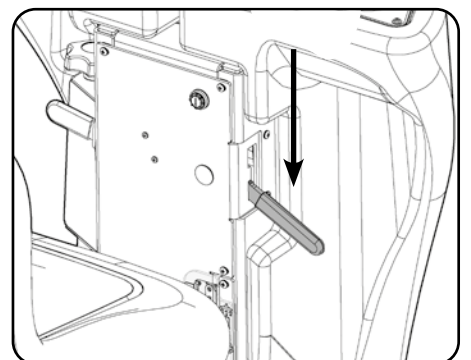

Raise the floor tool.



**Note:** Machine will not reverse with floor tool in the lowered position.



## Machine set-up guide



**ALWAYS ENSURE THAT THE MACHINE IS SWITCHED OFF BEFORE MAKING ANY ADJUSTMENTS**



### Fitting the side pod skirts

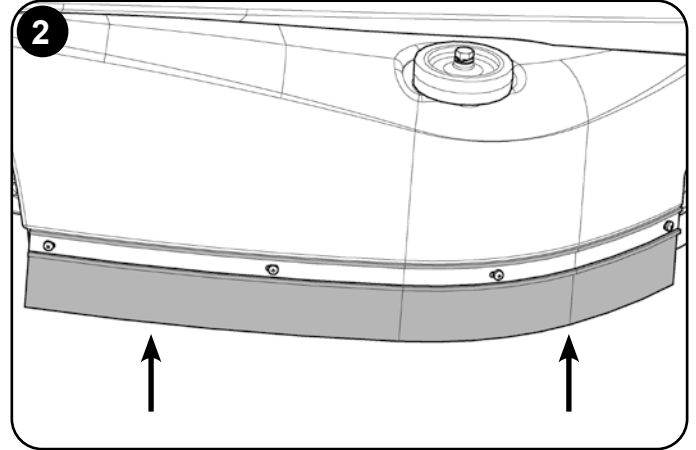
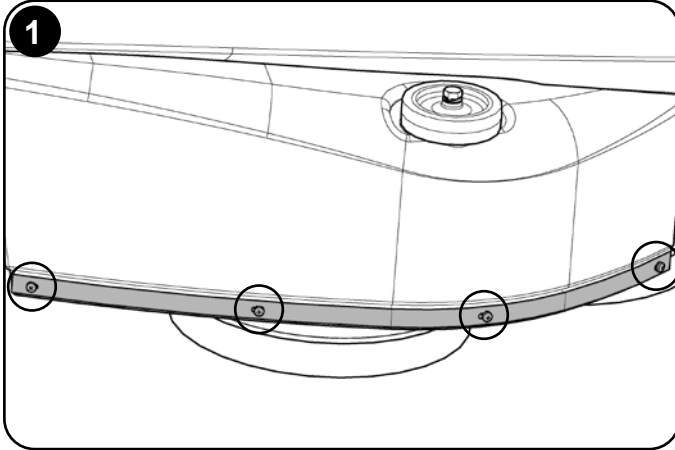

To fit the side pod skirts, first remove the steel retaining strip already fitted to the pod (Fig.1). Align the steel retaining strip within the locating grooves of the rubber skirt and refit using existing screws (Fig.2). Periodically the side skirts should be examined and checked for wear and damage. Replace as shown above.



**ALWAYS ENSURE THAT THE MACHINE IS SWITCHED OFF BEFORE MAKING ANY ADJUSTMENTS.**



### Fitting the brush

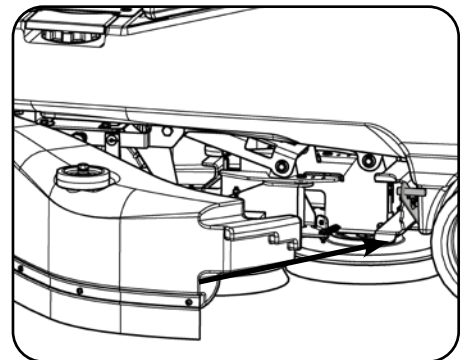
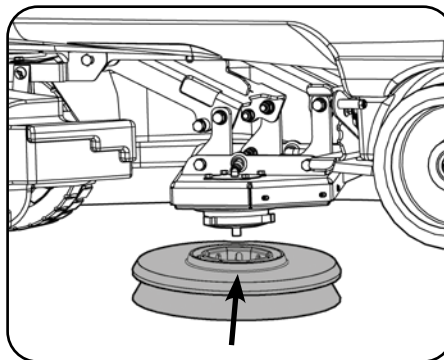
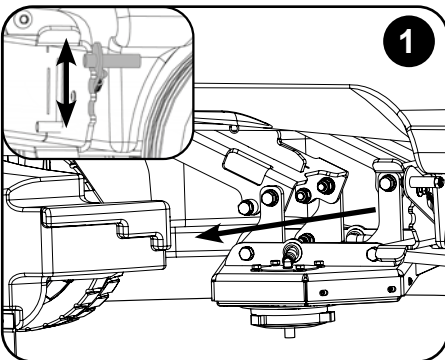

Pull the side pod lever and set to the top position (Fig.1). The side pod will now pull open. Slide brush under the chuck and raise into place, turn the brush anti-clockwise to locate and lock into position. Repeat the process with the second brush on the opposite side. Close side pod and move pod lever back into the locked position.

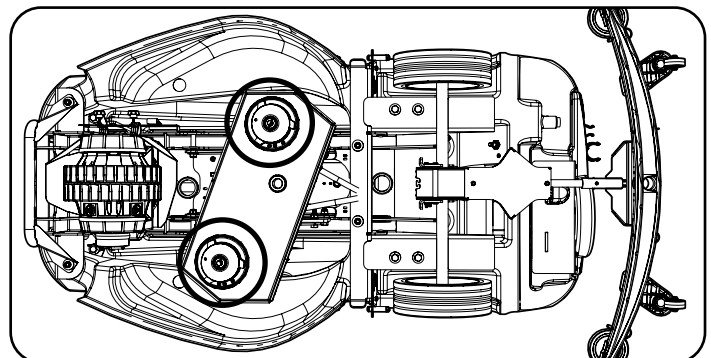

Brush location



**Safety gloves are recommended for the changing of used brushes.**

## Raise brush deck / Lower brush deck

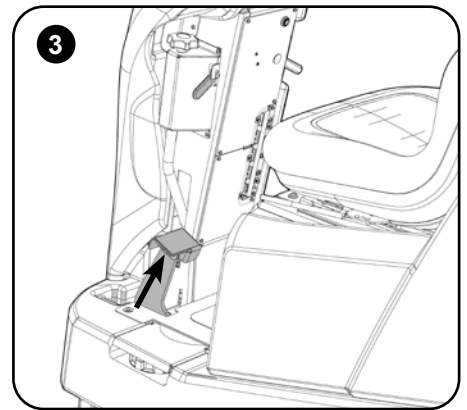
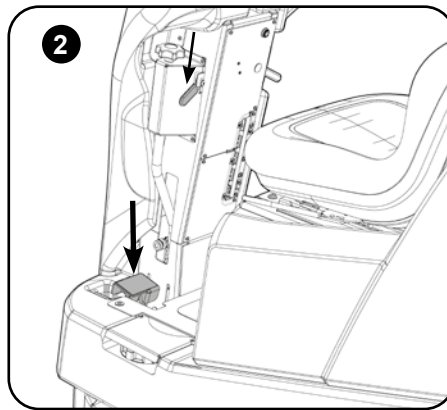
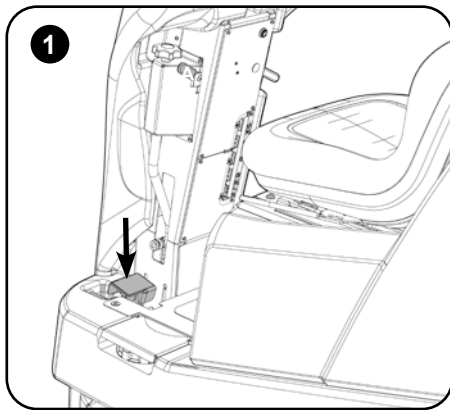

After preparing the floor, we are now ready to set the controls to suit the cleaning conditions.

Before any settings can be applied, ensure the brush deck is lowered.

While depressing left-hand foot pedal (1), press down the release lever (2) and gently release the foot pedal to lower the brush deck (3).

## Filling the clean water tank

The TRG 720 is equipped with a large capacity 120 litre clean water tank allowing for large areas to be covered in a single fill.

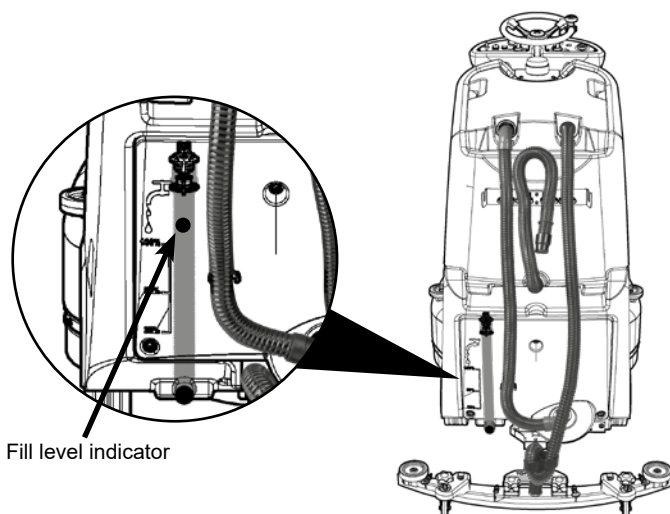
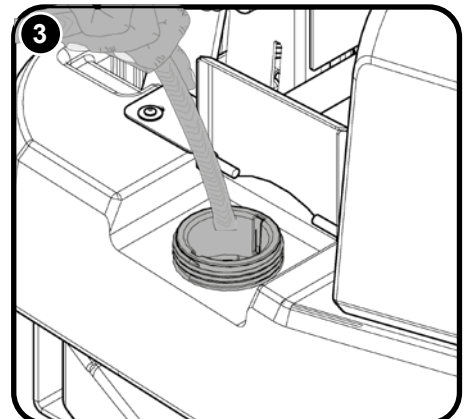
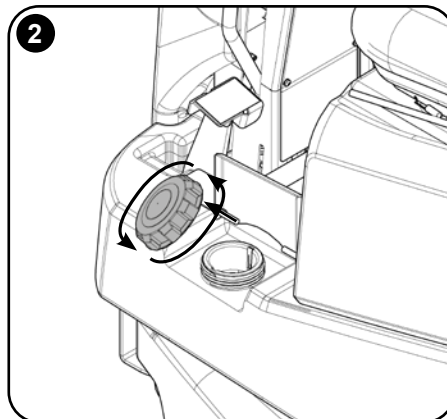
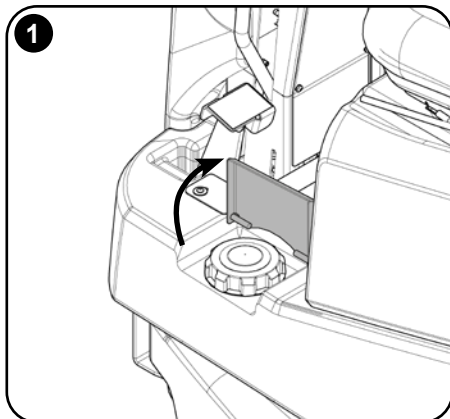

Fill level indicator

To fill the clean water tank, lift the cover flap (Fig.1) to expose the filler cap.

Unscrew the filler cap (Fig.2) and fill the tank using a hose (Fig.3) or preferred method. Add cleaning chemical to the tank following the manufactures guidelines.

*Note: A filter basket ensures that contaminants (i.e. leaves, hair, dirt, etc.) are not allowed to enter the clean water tank during the filling process. Periodically inspect and clean if necessary.*

### Fill-level indicator

The water level in the clean water tank can be measured using the visible red float inside the clean water dump hose on the rear of the machine.

Do not overfill the clean water tank.



**ALWAYS ENSURE THAT THE MACHINE IS SWITCHED OFF BEFORE MAKING ANY ADJUSTMENTS.**





## Machine set-up guide

### Adjusting the seat

Sitting in the driving position, adjust the seat forwards or backwards as necessary by using the lever found on the left-hand side (see Fig 1, 2, 3).

*Note: The seat is fitted with a pressure sensor that disables the machine until an operator is seated.*

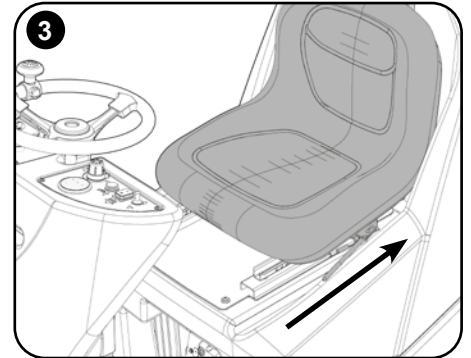
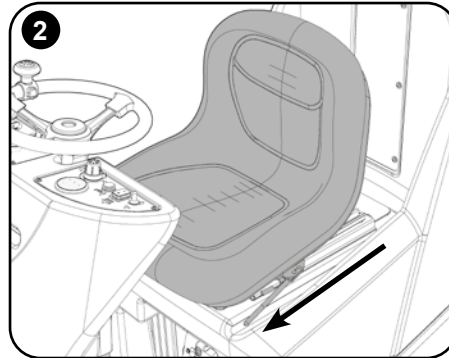
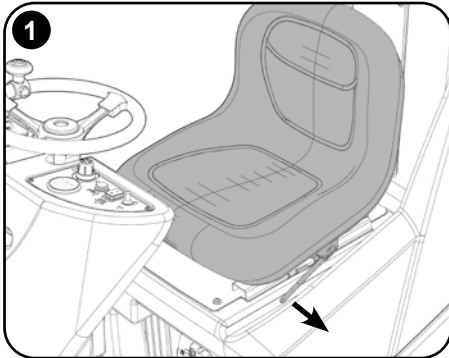

### Setting the cleaning controls

When in the area to be cleaned follow the instructions below to set up the machine ready for cleaning.

Sitting in the driving position follow steps 1 - 6.

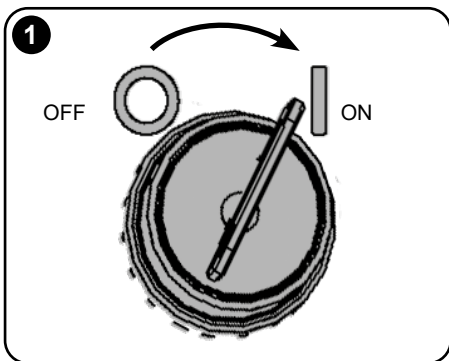

Insert the key into the ignition and quarter turn it clockwise to the 'ON' position. The battery charge level indicator will illuminate.

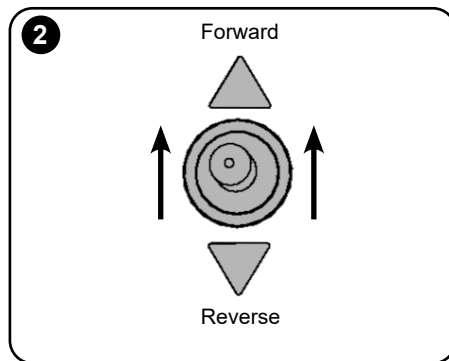

Set direction switch to forward.

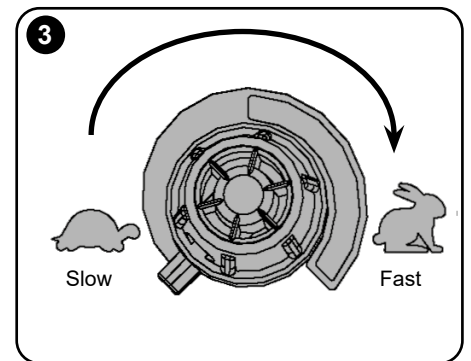

Turn dial to set desired cleaning speed.



**NOTE: MACHINE WILL NOT REVERSE WITH FLOOR TOOL IN THE LOWERED POSITION.**

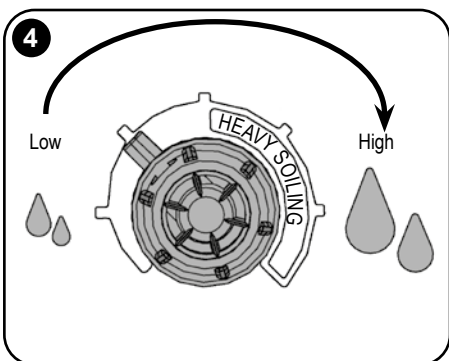

Turn dial to set desired water flow.

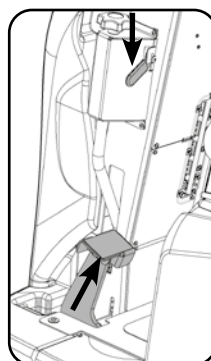

Lower brush deck by pushing down on the pedal, release handle and raise foot pedal.

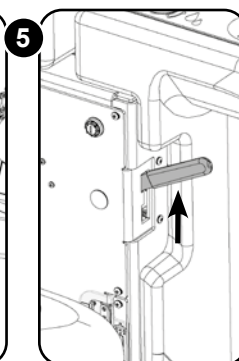

Lower floor tool by lifting lever upwards.

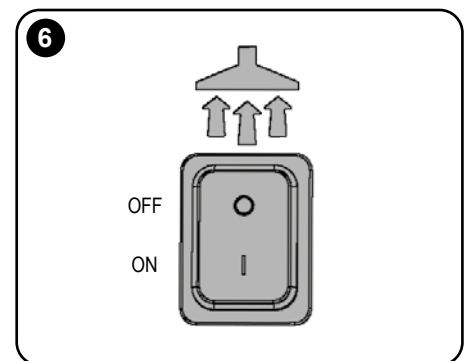

Press vacuum switch ON to turn on suction.

The machine is now set up and ready to start cleaning, depress the accelerator pedal to start the cleaning process. Adjust waterflow and speed according to floor type and level of soiling.



**IMPORTANT**  
**DO NOT OPERATE MACHINE UNLESS THE OPERATOR MANUAL HAS BEEN READ AND FULLY UNDERSTOOD.**



## Waste water tank full

The vacuum shut off system stops the airflow when the top waste water tank is full. A float ball rises as the water level rises, when the waste water tank is full the float ball blocks the vacuum hole to prevent any liquid entry.

The vacuum motor will continue to run, there is an audible difference in the sound when the waste water tank is full.

A secondary shut off will engage if the water exceeds the float ball shutting off the vacuum until the water level is lowered.

Located in your waste-water (top) tank is a full tank switch, this stops your machine from working once the waste-water reaches its maximum limit.

Sometimes the switch gets clogged and blocked, clean to ensure correct operation.

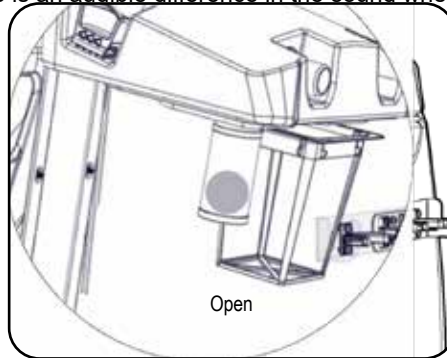

Open

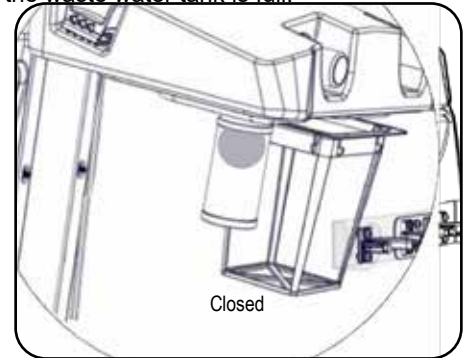

Closed

Float ball shut off

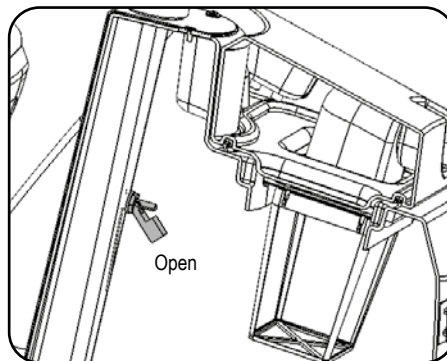

Open

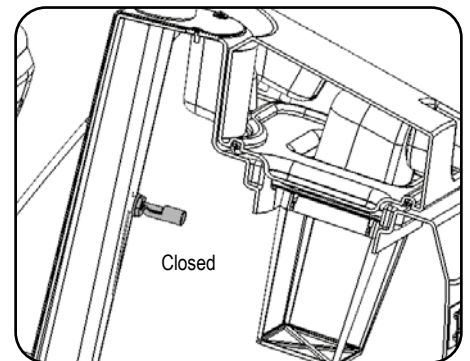

Closed

Full tank switch

## Emergency stop button / horn

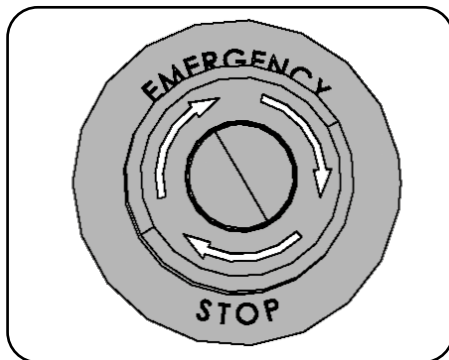

In an emergency, strike the emergency stop to disable the machine.

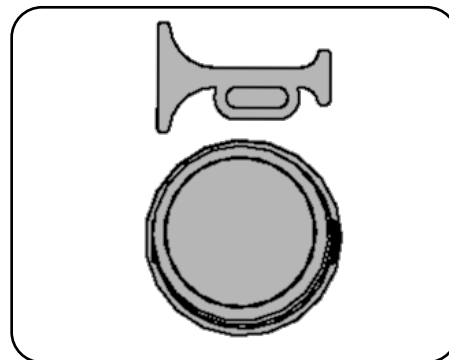

Horn button.

The TRG 720 is equipped with an electronic braking system.

To reset emergency stop button turn button clockwise, to restart the machine turn the key off then on again.

## Maximum speed control

Set desired traction speed as required, depending on floor type and level of soiling.

Once the Max speed has been set using the control knob on the control panel, fine adjustments can be made using the variable control speed pedal located on the right side of the footplate.

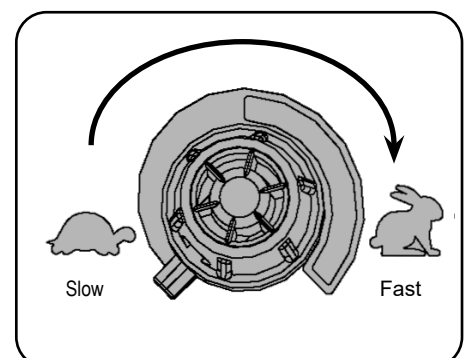



**DO NOT OPERATE THE MACHINE ON INCLINES THAT EXCEED 11%.**



## Machine in use

To operate, select forward and depress the accelerator pedal.

Vacuum pick-up and water flow will turn on if selected, and providing the brush and floor tool are in the lowered position, the machine will move forward.

Clean water is dispersed evenly via 'THRU- FEED' scrubbing brushes.

The waste water is then retrieved by the suction floor tool.

Overlap each scrubbing path by 10cm to ensure an even clean.

After stopping, let the vacuum motor run for 10 seconds to collect any water left in the vacuum hose, then switch the vacuum motor off.

On heavily soiled floors use a 'double scrub' technique.

First pre-scrub the floor with the floor tool in the raised position, allow the chemicals time to work, then scrub the area a second time with the floor tool lowered.

If your machine leaves streaks on the cleaned floor, either clean the floor tool blade or

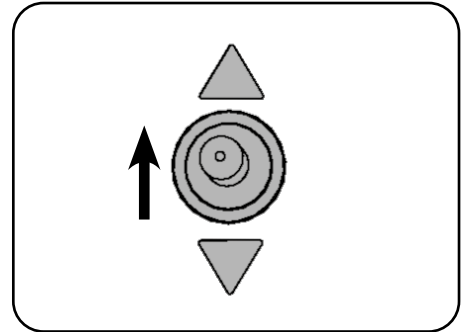

Set lever to forward.

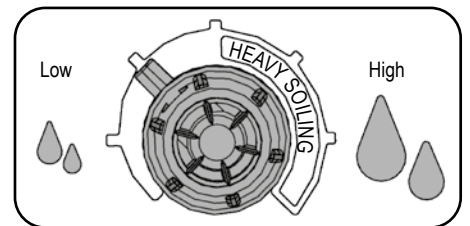

Water flow rate selection.



**NOTE: MACHINE WILL NOT REVERSE WITH FLOOR TOOL IN THE LOWERED POSITION.**

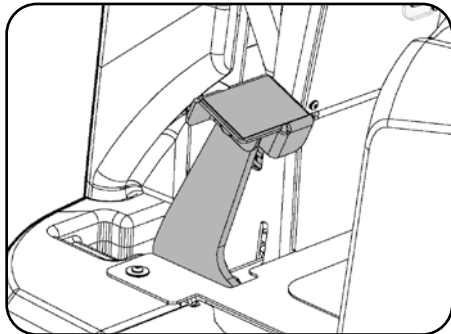

Brush deck in lowered position.

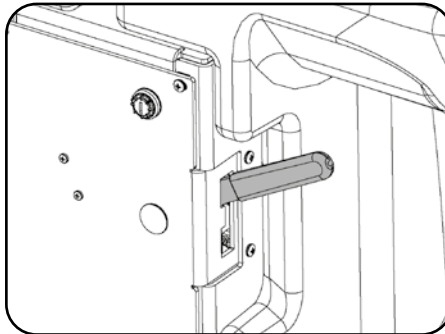

Floor tool lever in lowered position.

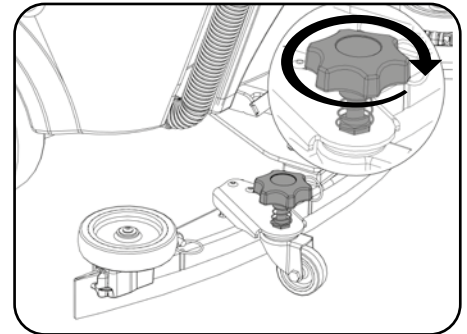

Adjusting the blade height.

## Off-aisle cleaning kit (optional extra accessory) 606182

The optional off-aisle cleaning kit gives added flexibility to the operator.

The kit can be used to clean hard to reach / inaccessible areas.

Remove the vacuum hose from the floor tool and attach to the off-aisle kit.

To operate the vacuum, press the vacuum switch on.

**NOTE: Return the hose to the floor tool once finished using the off-aisle facility.**

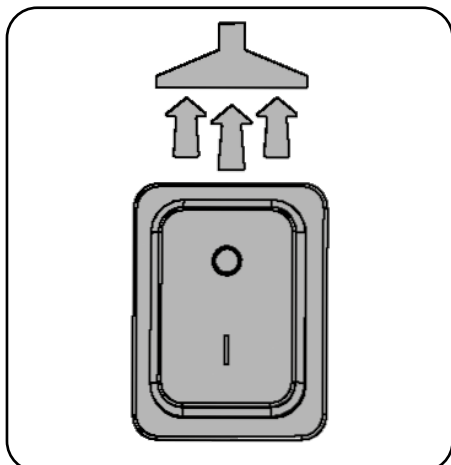

Off-aisle vacuum switch.

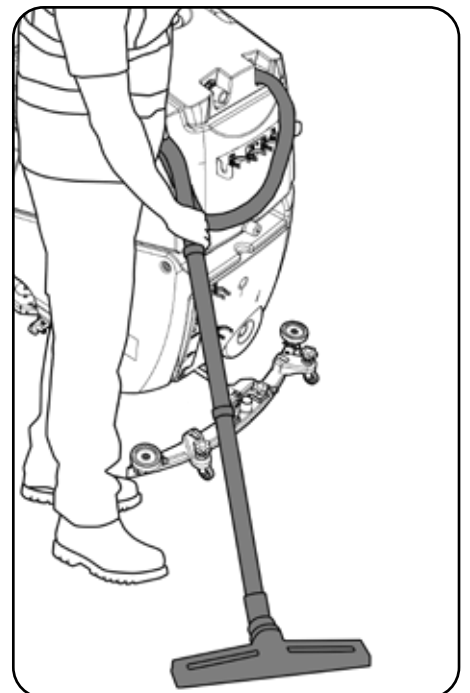

## Machine cleaning



**ALWAYS ENSURE THAT THE MACHINE IS SWITCHED OFF PRIOR TO ANY MAINTENANCE.**



- A** After use, empty waste water tank using emptying hose and flush-out with clean water.
- B** Remove floor tool vacuum hose ensuring you remove the U-bend clip and flush out with clean water.
- C** Empty clean water tank, using emptying hose and again flush out with clean water.

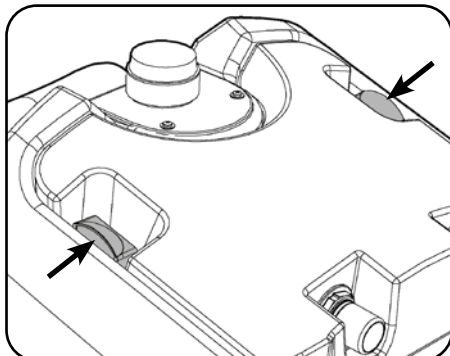
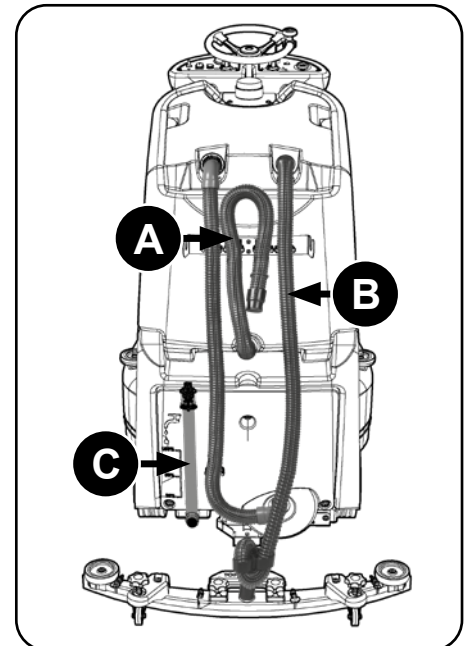

Push in the 2 retaining handles of the separator.

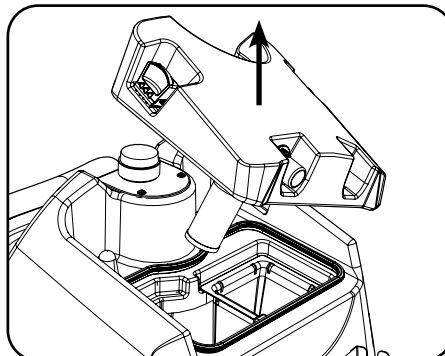

Holding the handles lift the separator away.

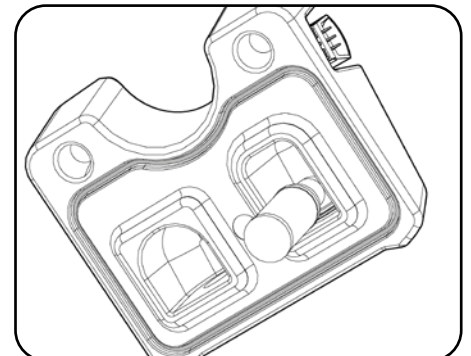

Clean and examine rubber seal during each clean.

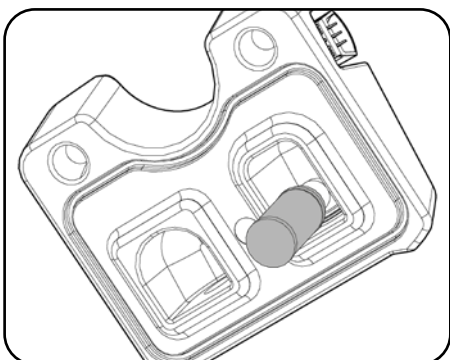

Remove and clean vacuum shut off filter.

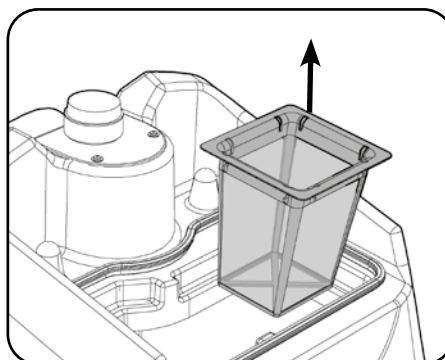

Remove large debris filter, clean and replace.

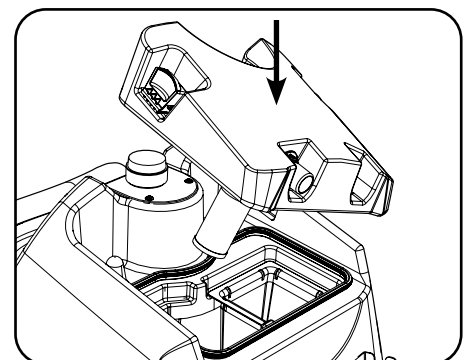

After cleaning, refit the separator and reconnect the hoses.

Located in your waste water top tank is a vacuum shut off system, this prevents suction when the waste water tank is full. It also prevents foam created by high-foaming detergents from entering the motor. Sometimes the float vents get clogged and blocked, clean to ensure correct operation. Remove debris basket filter and rinse using clean water, and refit. Refit both of the vacuum hoses.



**IMPORTANT: IF THE DEBRIS BASKET IS ALLOWED TO BECOME CLOGGED, VACUUM PERFORMANCE CAN DETERIORATE.**





## Machine cleaning



**ALWAYS ENSURE THAT THE MACHINE IS SWITCHED OFF PRIOR TO ANY MAINTENANCE.**



The clean water pump filter is located to the rear of the battery compartment, and should be checked before each use. Lift the filter off of the cradle, unscrew the bottom and remove, taking care not to spill any liquid on to the batteries.

Rinse using clean water and refit, refitting is reversal of removal.

*NOTE: Any spills should be wiped up before tank is lowered.*

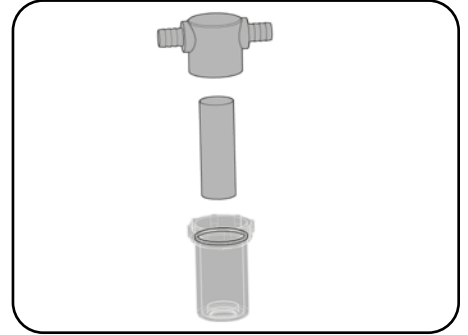
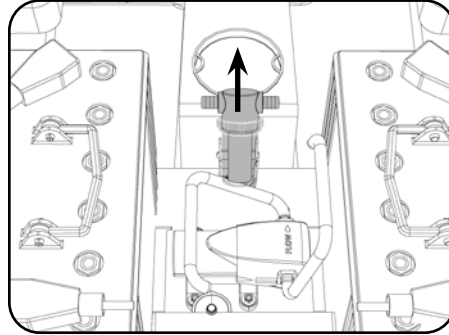
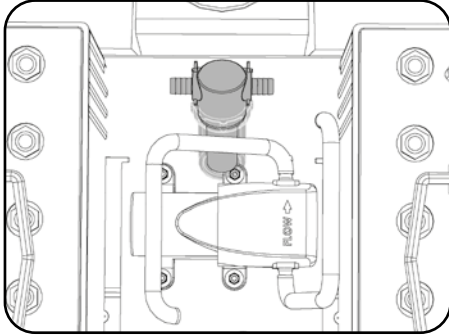

## Fuses

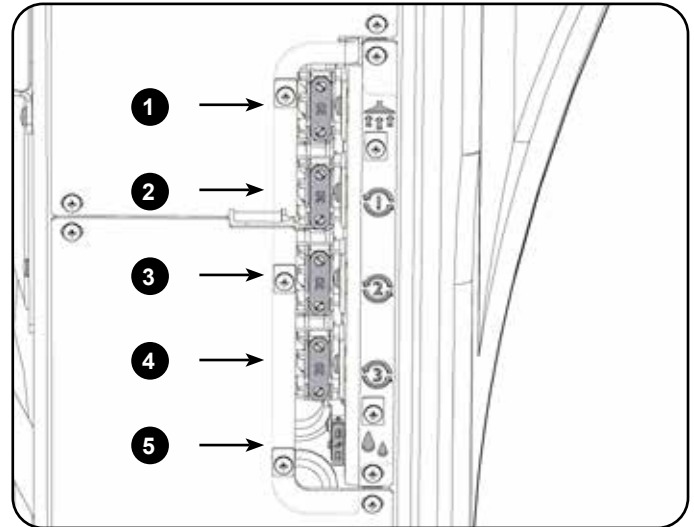
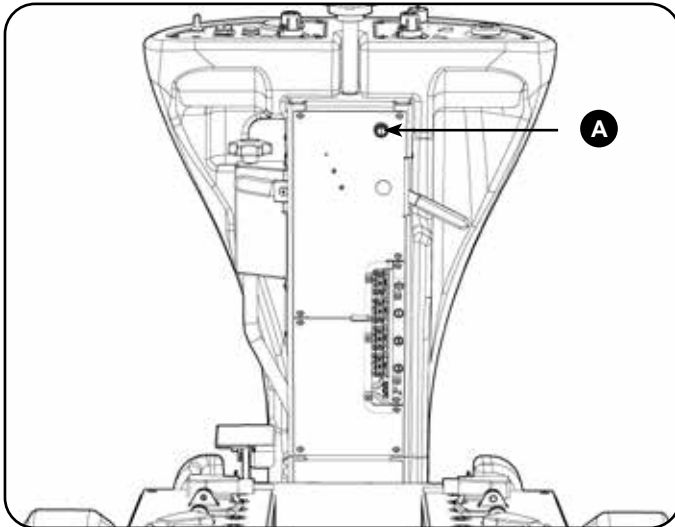

Located on the inside of the steering column is the machines fuse box containing the fuses.

To the right of the fuses are the symbols identifying what the fuse links to.

Fuses in order:

- A - 2.5 Amp safety fuse
- 1 - 20 Amp fuse for Vacuum Motor
- 2 - 30 Amp fuse for Motor Brush 1
- 3 - Not fitted
- 4 - Not fitted
- 5 - 4 Amp fuse for Water Pump.

## Changing the floor tool blades



**ALWAYS ENSURE THAT THE MACHINE IS SWITCHED OFF PRIOR TO ANY MAINTENANCE.**



Lower the floor tool then unscrew the retaining knobs and slide it off the holding bracket.

Rinse the floor tool assembly with clean water and refit.

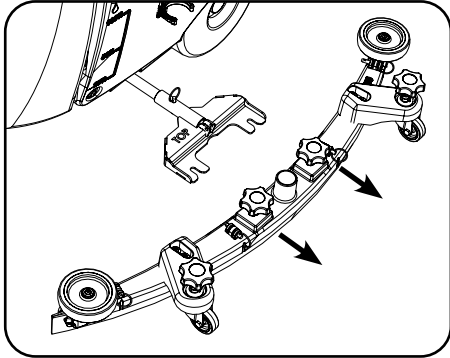

Remove floor tool.

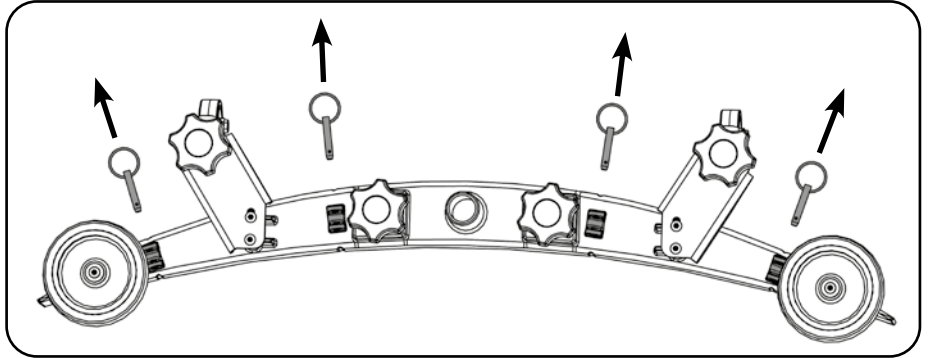

Remove four retaining pins.

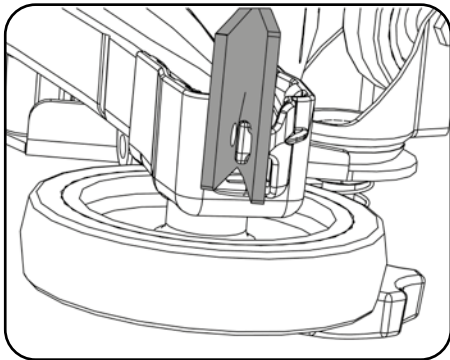

Turn the floor tool over.

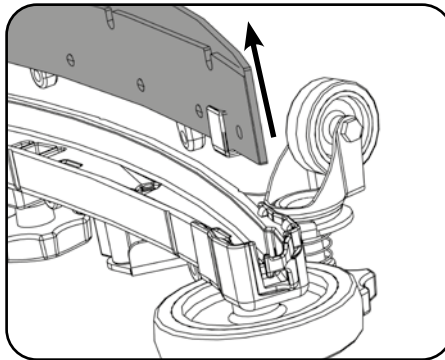

Separate the blade carrier from the main body.

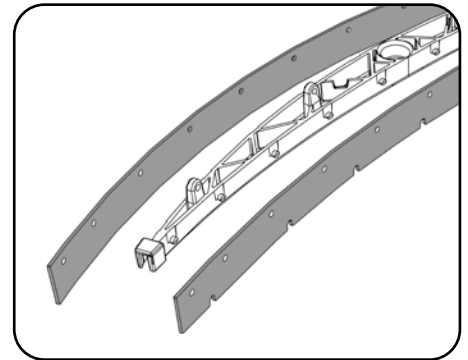

Peel away blades.

Periodically the floor tool blades should be examined and checked for wear and damage.

Replacement is a reversal of the removal process.

### Floor Tool Overview

1. Front blade (slotted)
2. Blade carrier
3. Rear blade
4. Floor tool main body
5. Retaining pins x 4

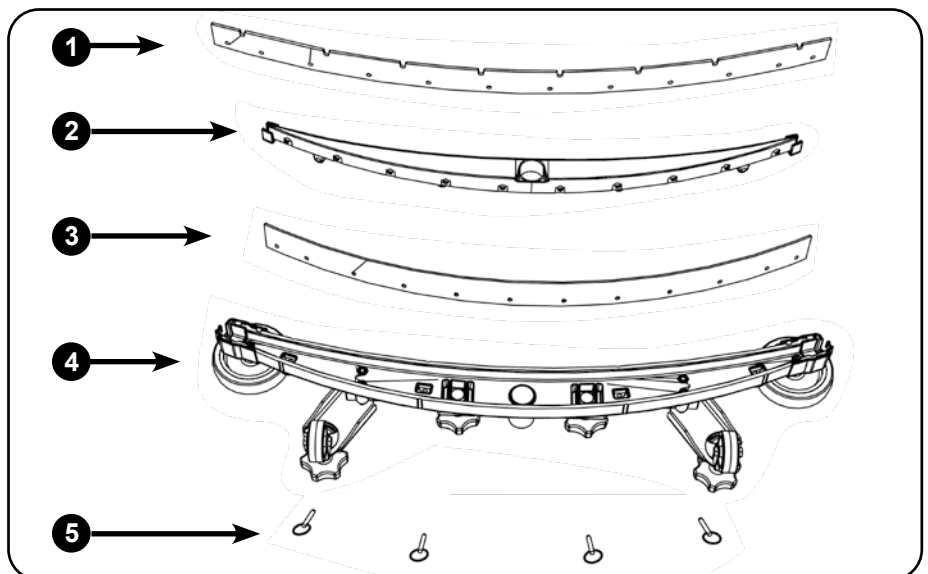

**Note: THE BLADES ARE DESIGNED TO BE REVERSIBLE, THUS EXTENDING THEIR USEFUL WORKING LIFE.**



## Free wheel and towing

**ALWAYS ENSURE THAT THE MACHINE IS ON LEVEL GROUND BEFORE DISENGAGING BRAKE ARM. NEVER DISENGAGE THE BRAKE WHEN THE MACHINE IS ON A SLOPE / GRADIENT. NEVER TOW THE MACHINE WITH THE BRAKE ENGAGED AND POWER PLUG CONNECTED! REMOVE BATTERY FUSES**

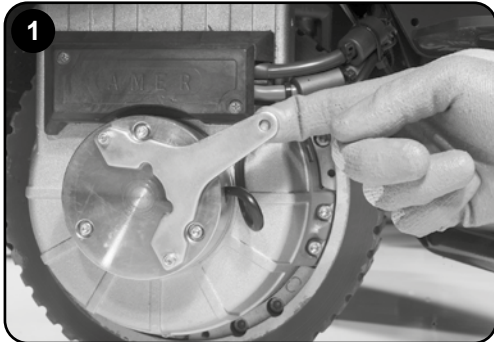

The TRG 720 / 200T and TRG 720 / 300T is equipped with a free wheel function that will enable the operator to move / tow the machine. The motor brake is disengaged by opening the brake arm on the side of the drive wheel (see Fig.1).

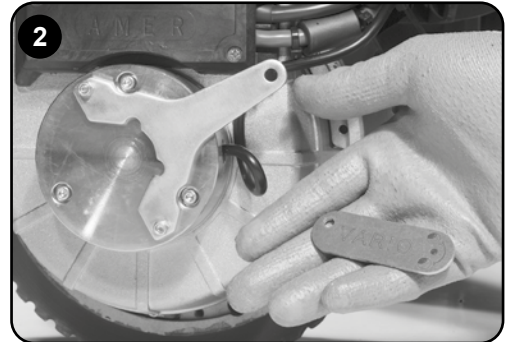

Your start-up kit includes a brake drive disengage key (329945, see Fig.2) which can be inserted between the brake arm and drive housing (see Fig.3).



Once the key has been inserted (see Fig.3) the motor brake will be fully disengaged. The machine will now be in full free wheel mode.

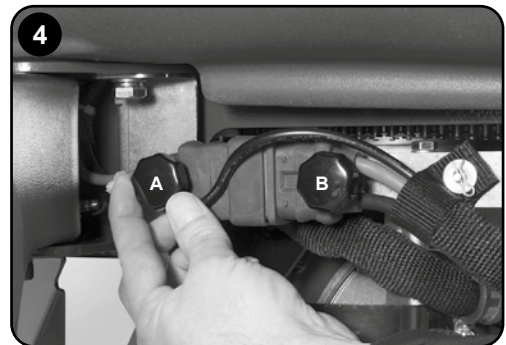

Undo and remove the two retaining knobs (fig.A&B). Remove battery fuses.



Pull the power connector block apart and refit the two retaining knobs. When destination place reached, remove brake disengage key, connect power plug, fit fuses.

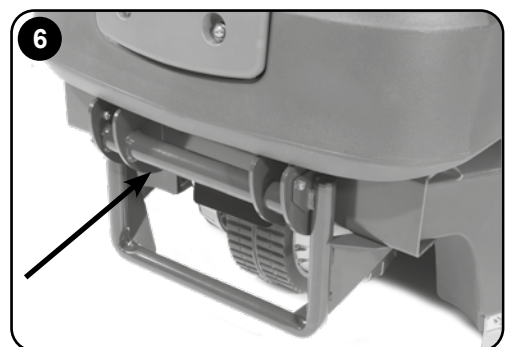

When towing the machine ensure that a suitable tow bar is used. Care must be taken when towing; **WHEN TOWING DO NOT EXCEED AVERAGE SPEED OF 3 KPH.** The machine can be towed from the front bar as indicated (see Fig.6).

### WARNING!

**WHEN THE BRAKE IS DISENGAGED AND POWER PLUG IS DISCONNECTED THE MACHINE IS IN FREE WHEEL MODE AND HAS NO BRAKE FACILITY, WHEN TOWING THE MACHINE ENSURE THAT A SUITABLE TOW BAR IS USED.**

**Remember to remove the brake disengage key when you reach your final destination / before using the machine. NOT FOLLOWING DESCRIBED METHOD COULD DAMAGE MAIN CONTROL UNIT AND VOID THE WARRANTY.**

# Machine charging

**! ALWAYS ENSURE THAT THE MACHINE IS SWITCHED OFF PRIOR TO CHARGING. !**

1. The battery meter displays the charge level of the batteries; when fully charged, all meter lights are illuminated.

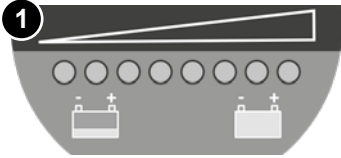

2. As the machine is used and the batteries are discharged, the meter lights will go out from right to left.

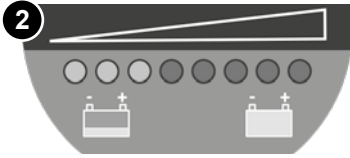

3. When the battery meter turns RED the vacuum motor and the brush motor will stop. Once the motors have stopped, turn off the vacuum motor and lift the brush deck. Turn the key off then back on. If required switch the vacuum motor on to pick up any remaining liquid. Take machine to charging location and place on charge. Ensure the vacuum motor is switched off and the machine is turned off by the key before charging.

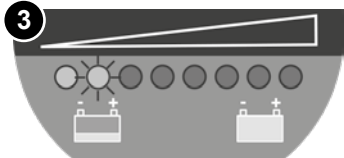

Insert the charging lead required for your country into the charging point. The machine charging point is located to the rear of the machine under the control panel. Connect to a suitable power supply. Once mains power is connected the red charging indicator will illuminate. To ensure a full charge, the machine should be left for a period of 8-10 hrs (200Ah) & 12-14h (300Ah). Once fully charged, disconnect the charging lead from both the power supply and the machine.

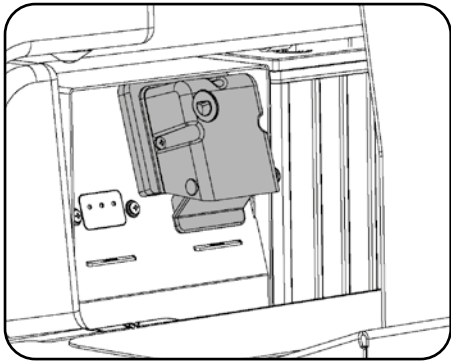

Machine charging point, above footplate.

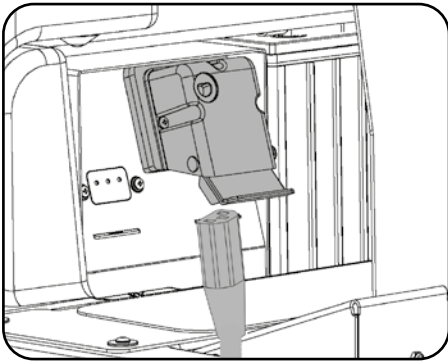

Insert country specific charging lead.

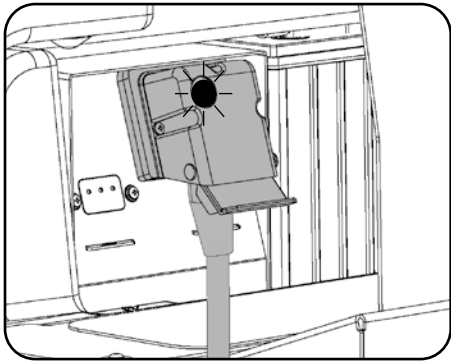

Red charging indicator illuminates when charging.

The large capacity gel batteries are sealed for life and are totally maintenance free. The on-board charger automatically monitors the charging process and will switch off when the batteries are fully charged.

*NOTE: The charging lead supplied with your machine may differ than the lead shown.* Once the charging lead has been connected the machine will be INHIBITED. The battery charge indicator display lights will show the current charge state. To ensure a full charge, the machine should be left until the charging indicator shows green. Once fully charged, disconnect the charging lead from both the power supply and the machine.

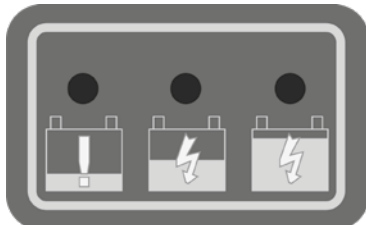

Charging indicator (see page 17)

## External charging point

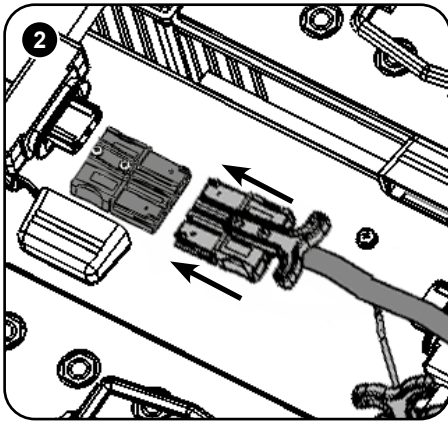
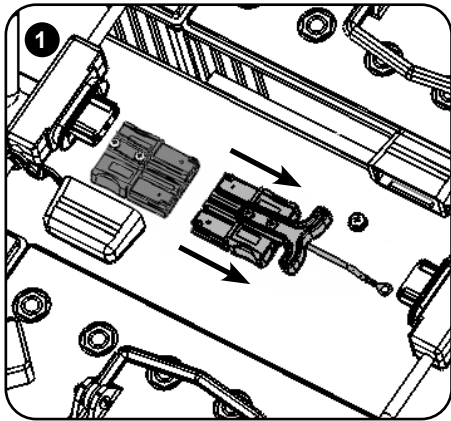

**ALWAYS ENSURE THE MACHINE IS SWITCHED OFF PRIOR TO CHARGING.**

Recharge batteries after each use, regardless of machine operation time.

The machine charging point is located under the top tank in the centre of the machine.

Remove Isolator Plug (1) and connect your external charger (2).

Refit Isolator Plug before operating the machine.

**! NOTE: ONLY USE THE RECOMMENDED CHARGER AND LEADS. CONTACT NUMATIC INTERNATIONAL LTD FOR RECOMMENDED CHARGER AND LEADS. !**



## Battery care



**TO ENSURE YOUR MACHINE REMAINS AT ITS MAXIMUM EFFICIENCY AND PROLONG YOUR BATTERY LIFE, PLEASE FOLLOW THE SIMPLE STEPS BELOW:**



### UNDER NORMAL DAILY USAGE:

Re-charge the machine FULLY after each use regardless of machine operation time.

Do not leave the machine in a discharged state.



Periodically inspect the battery connections for tightness and corrosion.

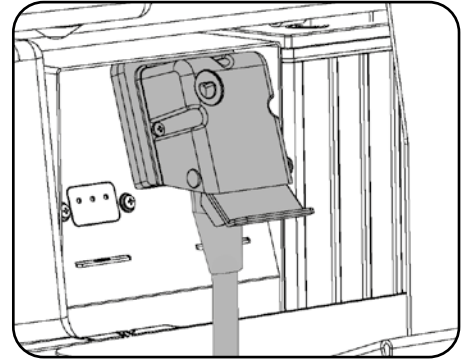

## Charging light sequence

Signal (LED)	Meaning
Red LED on	First phase (constant current mode)
Orange LED on	Second phase (constant voltage mode)
Green LED on	Third phase (constant voltage mode) charge complete
Red LED flashing followed by Pause	Cooling fan locked > 1 flash between pause Over voltage protection / Output short circuit / Battery reverse polarity > 2 flashes between pause Over temperature protection > 3 flashes between pause Charge time has exceeded 16 hrs during phase 1 or 2 > 4 flashes between pause

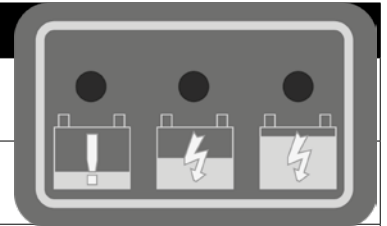

### Under abnormal use:

i.e. leaving the machine without charging for a period of time, we advise that you follow these steps:

If the machine will be standing unused for a period of 30 days or more, then batteries must be fully charged and battery fuse removed using the maxi fuse-puller provided, prior to this period.

Batteries should be recharged every three months.

Charge fully the day before you start using the machine again.

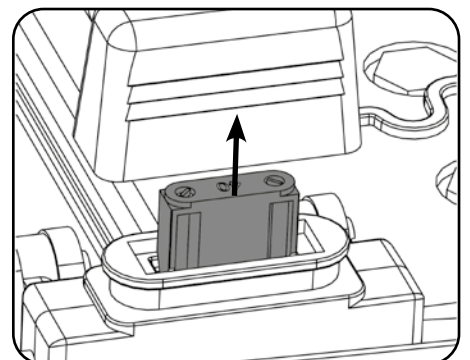

Green Status Indicator		Fault		Possible Cause		Effect on Product		Investigate the Following		Action Required		If Fault Persists	
1 Flash with pause	Batteries voltage low	Batteries not been charged Possible bad connection between batteries, controller, charger or fuses caused by loose connections, damaged wiring, water ingress Not accepting charge due to faulty battery / cell Charger not functioning	Operating time severely reduced or machine will not operate	Check when machine last charged Switch OFF the machine : Remove fuses Check connections to batteries, charger and fuses for loose wires or screws Check each battery voltage individually to detect defect unit 10.5V min	Charge batteries immediately Tighten loose connections and replace damaged components Replace batteries as required								
2 Flashes with pause	Traction motor disconnected	The motor has a bad connection Motor disconnected TCO activated (Thermal Cut Out) Motor failed to open circuit	The motor will not operate	Check all connections and leads between motor and controller Check battery voltage and charge current ensuring charger red fault light is extinguished Check each battery voltage individually to detect defect unit 10.5V min	Tighten loose connections and replace damaged components Replace charger								
3 Flashes with pause	Traction motor wiring trip	The motor has a short circuit to a battery	Motor will not operate	Check all connections and leads between the motor and controller									
4 Flashes with pause	Battery Lockout	The battery charge level has fallen below the battery lockout level and the controller is inhibiting machine functions	Machine functions not working	Check battery voltage and charge current ensuring charger red fault light is extinguished Check each battery voltage individually to detect defect unit 10.5V min	Charge batteries immediately								
6 Flashes with pause	Charger connected	The controller is being inhibited from driving, this may be because the battery charger is connected	Machine functions not working	Remove charger to operate machine									
7 Flashes with pause	Machine inhibited	E-Stop pressed	Machine functionality inhibited	Check E-Stop	Release E-Stop and cycle key switch								
8 Flashes with pause	Machine inhibited	Accelerator pedal pressed on start up	Machine functionality inhibited	Remove foot from pedal. Check mechanism	Cycle key switch								
9 Flashes with pause	Controller trip	A controller trip is indicated	Machine functions not working	Check all connections and leads	Tighten loose connections and replace damaged components								
9 Flashes with pause	Brake deactivated or failed	Poor brake connections brake failure or deactivation	Traction drive disabled	Check brake wiring and brake lever	Replace brake or wiring as necessary. Reactivate brake by engaging brake lever								
10 Flashes with pause	High battery voltage	Poor connections between battery controller and traction motor	Machine functions not working	Check each battery voltage individually to ensure voltage < 14 volts Check connections on controller batteries and traction motor Check combined battery pack voltage is < 28 volts									

Contact service agent

# Specifications

## Model - TRG 720 200T / 300T

(Empty) Net Weight 200 Ah / 300 Ah	Brush Weight	Brush Width	Brush Pressure	Pad Width	Pad Pressure	Brush Motor	Vac Motor (24V)
TRG 720 / 200 - 357 kg TRG 720 / 300 - 422 kg	32 kg	720mm (2 x 370mm)	19.9 G/cm <sup>2</sup>	700mm (2 x 360mm)	16.6 G/cm <sup>2</sup>	24 V 600 W	2 - Stage: 400W
Gross weight 200 Ah / 300 Ah 120L + 80kg operator	Drive Motor	Max Run Time 200Ah 24V (4 x 100Ah)	Max Run Time 300Ah 24V (6 x 100Ah)	Battery Weight 200Ah 24V (4 x 100Ah)	Battery Weight 300Ah 24V (6 x 100Ah)	Charge Times 200Ah 24V (4 x 100Ah)	Charge Times 300Ah 24V (6 x 100Ah)
TRG 720 / 200 - 557 kg TRG 720 / 300 - 622 kg	24 V 700 W	3.5 Hrs	5.5 Hrs	124Kgs	186Kgs	20A = 8 - 10 hrs 25A = 6 - 8 hrs	20A = 12 - 14 hrs 25A = 9 - 11 hrs
Brush Speed	Air Flow	Transit Speed	Capacity	Water Flow Rates	Cleaning Area	Sound Pressure	
150 rpm	2-Stage 24.2 L/Sec	0-6 Km/hr	120L / 120L	0 - 3.5 L/min	2200m <sup>2</sup> @ 3.5 K/Hr	≤ 70dB (A)	
Hand Arm Vibration	Whole Body Vibration	Height	Length	Width	Ingress Protection	Max Gradient	
Travelling (Cleaning Mode) ah ≤ 2.5m/s <sup>2</sup> ISO 5439-1	Travelling (Cleaning Mode) aw ≤ 0.5m/s <sup>2</sup> ISO 2431-1	1385 mm	1752 mm	948 mm	IPX3	11%	

# Trouble shooting

PROBLEM	CAUSE	SOLUTION
Machine will not operate	Missing or blown fuses Low battery charge Machine is connected and charging Key is off or missing Handle safety fuse blown	Fit or replace fuse (page 3 / 5 & 13) Charge batteries (page 15 / 16) Take off charge (page 15) Insert key & turn to operating position (page 5 & 9) Replace fuse - (page 2 / 3 & 13) (or contact service engineer)
Vacuum will not operate	Missing or blown fuse Vacuum switch not engaged Waste water tank full	Fit or replace fuse (page 3 / 5 & 13) Press switch (page 11) Empty waste water tank (page 12)
Poor water pick-up	Waste water tank full Clogged / blocked vacuum hose Loose hose connections Debris basket filter clogged / blocked Separator filter clogged / blocked Poor separator seal Damaged separator seal Damaged / split vacuum hose Damaged floor tool blades Low battery charge Floor tool incorrectly adjusted	Empty waste water tank (page 12) Remove and clean (page 12) Push tight connections (page 3 / 6 / 12) Remove and clean (page 12) Remove and clean (page 12) Clean and refit (page 12) Renew (contact service dept) Renew (contact service dept) Renew (contact service dept) Re-charge batteries (page 16 / 17) Adjust floor tool (page 6 / 11)
No brush / scrub function	No brushes fitted Brush deck raised Missing or blown fuses	Check and fit (page 7) Lower brush deck (page 7 & 11) Fit or replace fuse (page 3 & 5)
Little or no water flow	Clean water tank empty Clean water tank filter blocked /clogged Water flow not on Brush deck raised Blown pump fuse	Fill clean water tank (page 8) Remove and clean (13) Switch on water flow (Page 9) Lower brush deck (page 7 & 11) Replace fuse - (page 2 / 3 & 13)
Machine just 'stops' during operating	Brush motor fuse blown due to high load Handle safety fuse blown	Replace fuse & reduce load (page 3 / 5 & 13) Replace fuse - (page 2 / 3 & 13) (or contact service engineer)

**Warning** Do not fit a replacement fuse link having a higher rating than the value stated on the fuse label.

**Failure to rectify the problem or in the event of a breakdown contact your Numatic dealer or Numatic Technical helpline +44 (0)1460 269268**

# About the machine

Rating Label	
1	Company Name & Address
2	Machine Description
3	Power Rating
4	Voltage Frequency
5	Max Gradient
6	Approvals Mark
7	WEEE Logo
8	Weight (Ready To Use)
9	Ingress Protection Rating
10	Machine YR/WK Serial Number
11	Machine Description
12	Noise Rating
13	Hand Arm Vibration

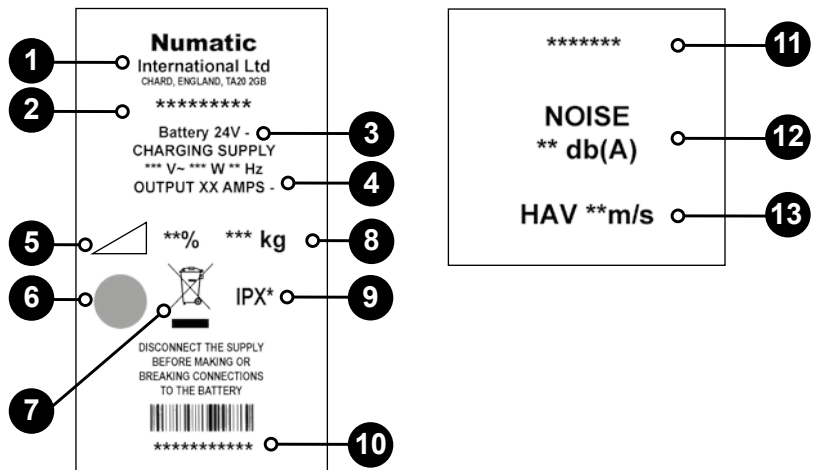

### WEEE (Waste, Electrical and Electronic Equipment)

Scrubber dryer accessories and packaging should be sorted for environmentally friendly recycling.

Only for EU countries.

Do not dispose of scrubber-dryer into household waste.

According to the European Directive 2012/19/EU on waste electrical electronic equipment and its incorporation into national law.

Scrubber-dryers that are no longer suitable for use must be separated, collected and sent for recovery in an environmentally-friendly manner.

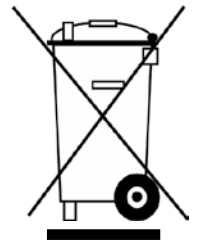

### PPE (Personal protective equipment) that may be required for certain operations.

Ear Protection	Safety Footwear	Head Protection	Safety Gloves	
Dust / Allergens Protection	Eye Protection	Protective Clothing	Hi-Vis Jacket	

Note: A risk assessment should be conducted to determine which PPE should be worn.

### Safety Critical Component:

Charging Leads: H05VV-F 3 Core x 1.0 mm<sup>2</sup>

Motor wheel & Brake: 904964

Battery Charger: (230V), (115V)





ORIGINAL INSTRUCTIONS  
READ MANUAL BEFORE USE

## Information for scrubber dryer



As with all electrical equipment care and attention must be exercised at all times during its use, in addition to ensuring that routine and preventative maintenance is carried out periodically in order to ensure its safe operation.

Failure to carry out maintenance as necessary, including the replacement of parts to the correct standard could render this equipment unsafe and the manufacturer can accept no responsibility or liability in this respect.

When ordering spare parts always quote the Model Number / Serial Number specified on the Rating Plate.

This appliance is not intended for use by persons (including children) with reduced physical, sensory or mental capabilities, or lack of experience and knowledge, unless they have been given supervision or instruction concerning use of the appliance by a person responsible for their safety. Children should be supervised to ensure that they do not play with the appliance.

If this product does not have a factory installed Numatic battery charger and batteries then it is the responsibility of the owner and user of the product to ensure that the charging system and battery combination are compatible, fit for purpose and safe to use.

Only use brushes provided with the appliance or those specified in the instruction manual.

The use of other brushes may impair safety.

A full range of brushes and accessories are available for this product.

Only use brushes or pads which are suitable for the correct operation of the machine for the specific task being performed.

It is essential that this equipment is correctly assembled and operated in accordance with current safety regulations.

When using the equipment always ensure that all necessary precautions are taken to guarantee the safety of the operator and any other persons who may be affected.

Wear non-slip footwear when scrubbing. Use a respiratory mask in dusty environments.

The machine, while charging, must be positioned so that the mains plug is easily accessible.

Remove the key from the ignition when cleaning and carrying out routine maintenance.

In order to prevent unauthorised use of the machine, the power source shall be switched off or locked, for example by removing the key of the main switch or the ignition key.

When replacing major components the ignition key and battery fuses **MUST** be removed.

If this product does not have a factory installed Numatic battery charger and batteries then it is the responsibility of the owner and user of the product to ensure that the charging system and battery combination are compatible, fit for purpose and safe to use.

Machines left unattended shall be secured against unintentional movement.

When detergents or other liquids are used, read the manufacturer's instructions.

Operators shall be adequately instructed as to the correct use of the machine.



This machine is not suitable for picking-up hazardous dust.

Do not use on surfaces having a gradient exceeding that marked on the appliance.

The machine is not to be stored outdoors in wet conditions.

This machine is for indoor use only.

Read the instruction manual before using the appliance.

This product meets the requirements of IEC 60335-2-72.

NOTE: This machine is intended for commercial use, for example in hotels, schools, hospitals, factories, shops, offices and rental business.



- Ensure only competent persons unpack/assemble the machine.
- Keep your machine clean.
- Keep your brushes in good condition.
- Replace any worn or damaged parts immediately.
- Regularly examine the power cord for damage, such as cracking or ageing. If damage is found, replace the cord before further use.
- Only replace the power cord with the correct Numatic approved replacement parts.
- Ensure that the work area is clear of obstructions and / or people.
- Ensure that the working area is well illuminated.
- Pre-sweep the area to be cleaned.
- Remove the key when the appliance is not in use



- Use steam cleaners or pressure washers to clean the machine or use in the rain.
- Attempt machine maintenance or cleaning unless the power plug has been removed from the supply outlet, if the machine is in charge mode or remove the key if in normal use.
- Allow any inexperienced repairs. Contact your nearest service centre.
- Strain charger lead or try to unplug by pulling on charger lead.
- Leave the brush deck in the lowered position when not in use.
- Expect the machine to provide trouble-free, reliable operation unless maintained correctly.
- Run the machine over any power cables during operation.



## Precautions when working with batteries

1. Always wear protective clothing e.g. face visor, gloves and overalls when working with batteries.
2. Whenever possible always use a properly designated and well-ventilated area for charging.  
Do not smoke or bring naked flames into the charging area.
3. Remove any metallic items from hands, wrists and neck i.e. rings, chains etc. before working on a battery.
4. Never rest tools or metallic objects on top of the battery.
5. When charging is complete disconnect from the mains supply.
6. The machine must be disconnected from the supply when removing the battery.
7. To remove the batteries:- Disconnect machine from the mains supply (if charging), raise waste water tank and ensure batteries are isolated by removing fuses. Disconnect hoses from separator and tanks, undo battery terminals and remove batteries.
8. Only use genuine Numatic replacement batteries.
9. Do not allow the batteries to become fully discharged, it may not be possible to recharge them.
10. Do not allow one battery to be discharged separately to the other.
11. Do not mix batteries from different machines.
12. The batteries fitted to this product are Valve Regulated Lead Acid (VRLA) gel electrolyte type.  
The fitting of any other type of battery may cause a safety hazard.
13. The batteries must be removed from the machine before it is scrapped.
14. Dispose of the batteries safely in accordance with local government regulations.

## Battery care

1. Battery storage:
  - a. Batteries must be stored in a dry, level and clean location not exceeding a temperature range of 5°C to 25°C.
  - b. Batteries must be fully charged after 6 months when on-the-shelf and as a minimum every 3 months thereafter or if the battery voltage reduces to 12.6V.
  - c. Batteries must be put into use within 12 months of the date of manufacture, failure to do so will lead to reduced capacity in the field. (Battery date code) - silver label on the battery - (e.g. 1649) = Year - 2016 / Week - 49.
  - d. If a battery reaches 10.5V, irreversible damage has occurred. Under this condition, a battery should not enter into service and should be disposed of according to local authority guidelines.
2. During use:
  - a. Batteries must be recharged after every use regardless of machine run time
  - b. If the machine is to be left dormant for any length of time complete the following:
    - i. Fully charge the batteries and remove the battery fuses
    - ii. Every 3 months insert the fuses and recharge
    - iii. Do not leave batteries dormant for more than 6 months
3. Warranty:
  - a. Batteries are warranted for 600 cycles (2 Years) providing all battery care rules are followed
  - b. To claim warranty the following details must be supplied
    - i. Serial number of the machine
    - ii. Battery date code (Show picture of battery date code)
    - iii. Date purchased
    - iv. Proof of Purchase
    - v. Maintenance history and charging regime

## Notes

---



---



---



---



---

# Spare parts

BRUSHES		SIDE SKIRTS	
903994	370MM NYLOSCRUB BRUSH	206947	SPLASH SKIRT
903449	370MM POLYSCRUB BRUSH	HOSES	
900524	360MM NULOC2 DRIVE BOARD	908990	DUMP HOSE 1100MM X Ø38MM (top tank)
FLOOR TOOL		900901	HOSE CLOSURE REPLACEMENT (35MM-38MM STRETCH HOSE)
903853	750 TWINTEC ALUMINIUM FLOOR TOOL (38MM HOSE, RED TRIM, SERILOR BLADES)	908821	SUCTION HOSE 1700MM X Ø38MM
900519	ALUMINIUM 750 FLOOR TOOL.REPLACEMENT SERILOR GREEN POLYURETHANE BLADES	237718	HOSE GUIDE
KEYS		213060	VAC HOSE 1060MM X Ø38MM
907208	SPARE SET OF KEYS (010K95, FOR 020SCA1/907149)	903977	DUMP HOSE ASSEMBLY C/W RED HOSE CAP (bottom tank)
FUSES		237754	35-38MM BLACK HOSE CLIP
909022	TRG SPARE FUSE PACK	901916	28MM HOSE CLIP
SEAT COVER		GENERAL	
280001	RIDE-ON SEAT COVER	908342	TANK FILTER (RED)
STRAINER/FILTER		904197	RED BOTTOM TANK FILLING FILTER
208888	EXTENDED STRAINER	904198	RED FILLER CAP
208890	EXTENDED STRAINER CLEAR BOWL	206953	FLOOR TOOL DETENT PIN
208830	STRAINER GASKET	909396	FLOAT BASKET FILTER
208889	EXTENDED STRAINER 50 MESH SCREEN	CHARGING LEAD	
		221079	YELLOW CABLE EURO TYPE CHARGING LEAD
		220386	UK TYPE CHARGING LEAD

# Schematic Diagram

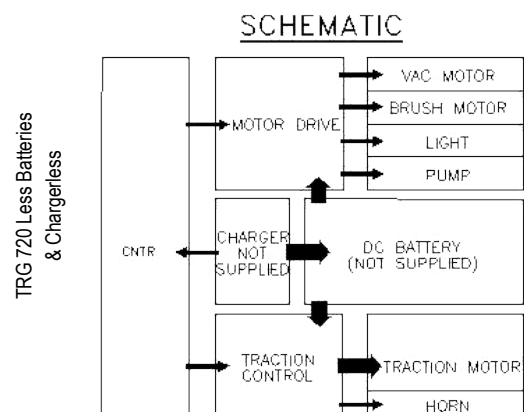
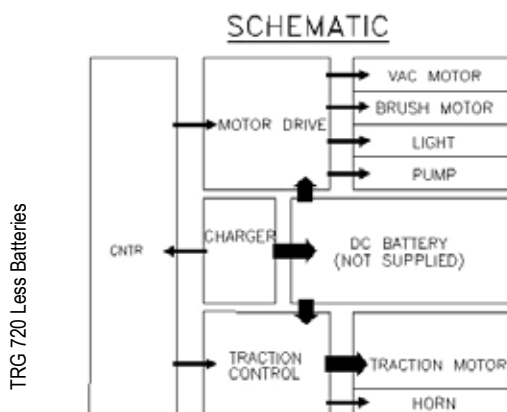
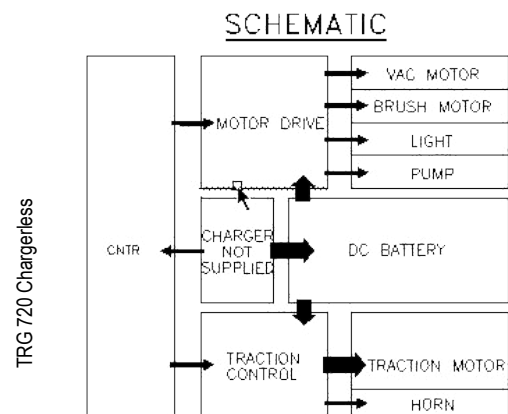
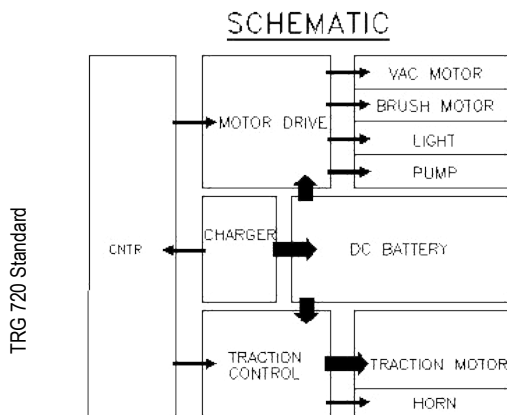

# Battery Wiring Diagram

4 Battery Wiring Diagram

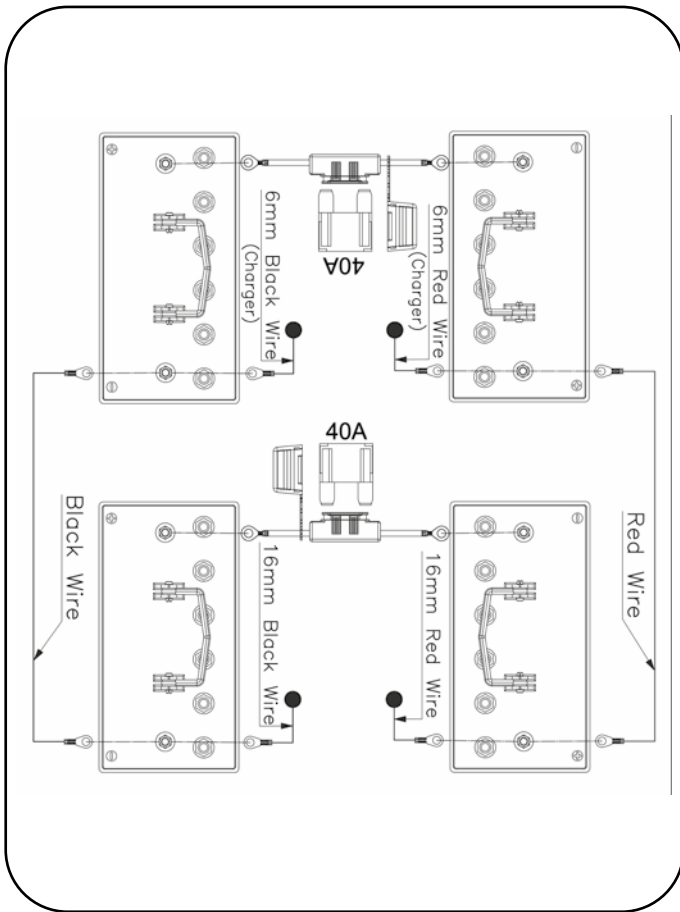

6 Battery Wiring Diagram

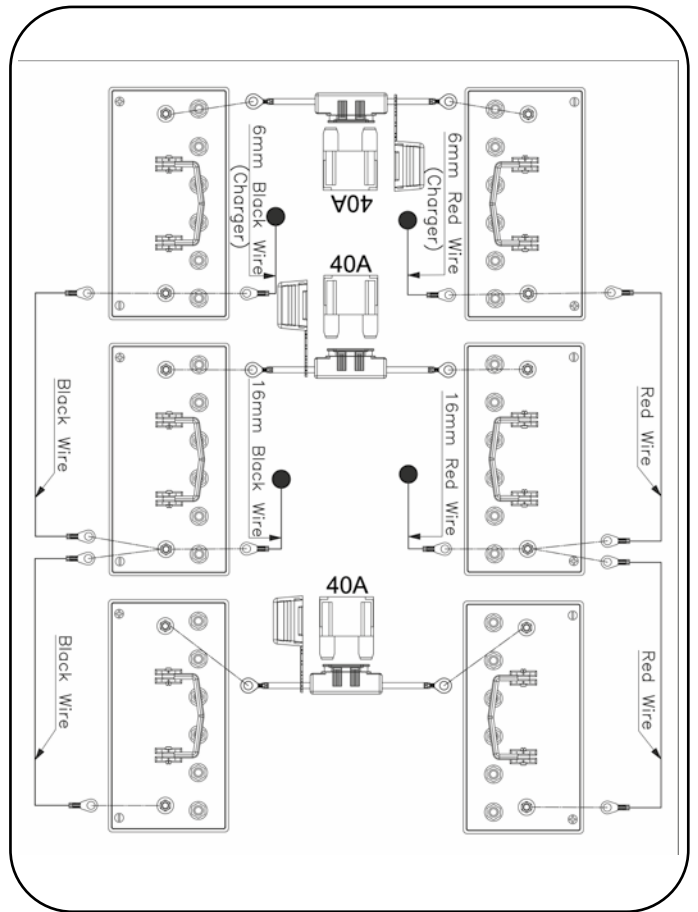

For optimum performance Numatic International Ltd recommend the use of the following batteries in the Twintec machines.

Machine	Numatic Recommended Battery	Numatic Number
TRG 720 / 200T Less Battery	MK Battery - 98A/h Stud Terminal Gel Type - Suppliers Ref: E31 SLD G ST	205112
TRG 720 / 300T Less Battery	MK Battery - 98A/h Stud Terminal Gel Type - Suppliers Ref: E31SLD G ST	205112

Make	Voltage	Capacity	Weight	Size
MK Battery	12 V	98 A/h	31.8 kg	327.5mm x 169mm x 218mm



# **Numatic International** *Warranty*

Numatic International Limited warrant to the original purchaser that its products are free of defects in both material or workmanship for the period shown below:-

Homecare and Cleancare Vacuum cleaners.....	2 Years
Rotary Floor Machines.....	2 Years
Twintec Auto Scrubber Dryer.....	1 Year
Vario Ride-On Scrubber Dryer.....	1 Year / 1500 hours
Mopping, Compacts, Combi and Servocare Products.....	1 Year
Individual Accessories and Spare Parts.....	6 Months

Note: This warranty expressly excludes consumable parts such as carbon brushes, floor brushes, mops, batteries etc, that are considered replaceable from time to time during the normal working life of the machine.

- A. The warranty period commences from the date the goods are purchased.
- B. All warranty claims must be processed through the Dealer from whom the equipment was purchased. The Dealer will co-operate with the purchaser throughout the warranty claims procedure and will arrange any necessary repairs using genuine Numatic parts.
- C. If the original Dealer is no longer able to fulfil his obligations please contact Numatic International Limited with full details of the claim and proof of purchase so that this may be processed without delay.
- D. Any warranty claim can only relate to the specific part that is proven to be at fault and for which a replacement will be supplied but cannot be extended to constitute a claim against the complete machine.
- E. Numatic International will supply the Dealer with any warranty parts required, subject to the claim being validated, after return of the faulty items in accordance with Numatic International Limited's General Conditions of Sale.
- F. Claims will not be accepted if they are the result of fair wear and tear, misuse or abuse of any kind.
- G. No replacement will be given unless the appropriate evidence of the validity of the claim has been provided to the satisfaction of Numatic International Limited.
- H. Numatic International Limited reserve the right to charge for any unnecessary work carried out as a result of an invalid claim.
- I. No variation to this warranty may be made or implied by any member of Numatic International Limited or its Dealers unless such variation is in writing and authorised by the Company



**Numatic International Limited. Chard, Somerset, TA20 2GB**

**Telephone: 01460 68600 Fax: 01460 68458**

© Numatic International Limited



<b>UKCA Declaration of Conformity</b>	
<b>Manufacturer:</b>	Numatic International Limited Chard Somerset TA20 2GB www.numatic.co.uk
<b>Product:</b>	TRG
<b>Description:</b>	Floor Treatment – Ride On – Commercial
<b>We, Numatic hereby declare under our sole responsibility, that the above-mentioned product(s) is/are in conformity with the following directives and standards.</b>	
<b>S.I. 2008: 1597</b>	<b>Supply of Machinery Regulations</b> EN60335-1:2012 + AC:2014 + A11:2014 + A13:2017 EN60335-2-72:2012 EN62233:2008
<b>S.I. 2016: 1091</b>	<b>EMC Regulations</b> EN55014-1:2017 + A11:2020 EN55014-2:1997 + A1:2001 + A2:2008 EN61000-3-2:2014 EN61000-3-3:2013
<b>S.I. 2012: 3032</b>	<b>RoHS Regulations</b>

Authorised Signatory: Mr. Matthew Coles Position: Head of Technology

Signed: *M Coles* Date: 1<sup>st</sup> Dec 2021

Numatic International Limited,  
Chard,  
Somerset, TA20 2GB, UK

DEC-056 V2.0

<b>EU, EC, EL, UE, ES:</b> <b>Declaration of Conformity</b> Prohlášení o shodě Konformitátselkiarung Overensstemmelseerklæring Declaración de conformidad Vastavuseklaratsioon Declaração de conformidade	Декларация за съответствие Діагностичний сертифікат Megfelelőségi nyilatkozat Dichiarazione di conformità Atitikties deklaracija Conformiteitsverklaring Samsvarserklæring Declaração de conformidade	Декларация за съответствие Діагностичний сертифікат Megfelelőségi nyilatkozat Dichiarazione di conformità Atitikties deklaracija Conformiteitsverklaring Samsvarserklæring Declaração de conformidade	
<b>Manufacturer:</b> / Výrobce / Hersteller / Fabricant / Fabricante / Toottaja / Fabricant / произвождател / Κατασκευαστής / Gyártó / Fabricante / Gamintojas / Fabrikant / Produzent / Fabricante / Producent / Producător / произвождател / Tillverkare / Proizvajalca / Valmistaja:	Numatic International Limited Chard Somerset TA20 2GB www.numatic.co.uk	Numatic International Limited Chard Somerset TA20 2GB www.numatic.co.uk	
<b>Product:</b> / Продукт / Produkt / Producto / Toodelt, Product / продукт / Товар / Termék / Prodotto / Produkta / Artikel / Produkt / Produkto / Produk / Produs / товар / Produkt / Izdelek / Tuote:	TRG	TRG	
<b>Description:</b> / Opis / Beschreibung / Beskrivelse / Description / Kirjeldus / La description / Описание / Περιγραφή / Leirás / Descrição / Apibūdinimas / Omschrijving / Beskrivelse / Descrição / Opis / Descrere / Описание / Beskrivning / Opis / Kuvasus:	Floor Treatment – Ride On – Commercial	Floor Treatment – Ride On – Commercial	
<b>We, Numatic hereby declare under our sole responsibility, that the above-mentioned product(s) is/are in conformity with the following directives and standards.</b>			
<b>CZ</b> My, Numatic prohlašujeme na svou výlučnou odpovědnost, že výše uvedený výrobek je ve shodě s následujícími směrnicemi a normami.	<b>DE</b> Wir, Numatic erklären in alleiniger Verantwortung, dass das oben genannte Produkt den folgenden Richtlinien und Normen entspricht.	<b>DK</b> Vi, Numatic erklærer hermed under eget ansvar at ovennævnte produkt(er) er i overensstemmelse med følgende direktiver og standarder.	<b>ES</b> Nosotros, Numatic declaramos bajo nuestra única responsabilidad que el producto antes mencionado está en conformidad con las siguientes directivas y normas
<b>EE</b> Meie, Numatic käesolevaga kinnitame ja kanname ainuisikulist vastutust, et eespool nimetatud toode on kooskõlas järgmistele direktiividele ja	<b>FR</b> Numatic déclare sous notre seule responsabilité que le produit mentionné ci-dessus est conforme aux directives et normes suivantes.	<b>GB</b> We, Numatic hereby declare under our sole responsibility, that the above-mentioned product(s) is/are in conformity with the following directives and standards.	<b>GR</b> Εμείς, Numatic δηλώνουμε με αποκλειστική μας ευθύνη, ότι το παραφορημένο προϊόν συμμορφώνεται με τις ακόλουθες οδηγίες και πρότυπα.
<b>HU</b> Mi, Numatic kijelentjük, egyedüli felelősséggel, hogy a fent említett termék megfelel az alábbi irányelveknek és szabványoknak	<b>IT</b> Noi, Numatic dichiariamo sotto la propria responsabilità, che il prodotto di cui sopra è conforme alle seguenti direttive e norme.	<b>LT</b> Mes, "Numatic pareikiu vienąšališką atsakomybę, kad pirmaui minėtas produktas atitinka šias direktyvas ir standartus	<b>NL</b> We verklaren Numatic hierbij op eigen verantwoordelijkheid, dat het bovengenoemde product voldoet aan de volgende richtlijnen en normen
<b>NO</b> Vi, Numatic erklærer herved under eget ansvar, at det ovennevnte produktet er i samsvar med følgende direktiver og standarder	<b>PT</b> Nós, a Numatic declaramos, sob nossa exclusiva responsabilidade, que o produto acima mencionado está em conformidade com as diretivas e normas a seguir.	<b>PL</b> My, Numatic Niniejszym oświadczamy z pełną odpowiedzialnością, że wyżej wymieniony produkt jest zgodny z następującymi dyrektywami i normami.	<b>RO</b> Noi, Numatic Prin prezenta declarăm pe propria răspundere, că produsul mai sus menționat este în conformitate cu următoarele standarde și directive.
<b>RU</b> Мы, Нифиць овим изъавляем под луном одговорноуцу, да наведенор производ је у складу са следећим директивама и стандардима.	<b>SE</b> Vi Numatic förklarar härmed under eget ansvar att ovan nämnda produkt överensstämmer med följande direktiv och normer.	<b>SI</b> Mi, Numatic izjavljam s polno odgovornostjo, da je zgoraj omenjeni izdelek v skladu z naslednjimi smernicami in standardi.	<b>FI</b> Me, Numatic täten vakuuttamme omalla vastuulla, että edellä mainittu tuote on yhdenmukainen seuraavien direktiivien ja standardien mukaisesti

<b>2006/42/EC</b>	<b>Machinery Directive</b> EN60335-1:2012 + AC:2014 + A11:2014 + A13:2017 EN60335-2-72:2012 EN62233:2008
<b>2014/30/EU</b>	<b>EMC Directive</b> EN55014-1:2017 + A11:2020 EN55014-2:1997 + A1:2001 + A2:2008 EN61000-3-2:2014 EN61000-3-3:2013
<b>2011/65/EU</b>	<b>RoHS Directive</b>

Authorised Signatory: Mr. Matthew Coles

Position: Head of Technology  
Numatic International Limited  
Chard,  
Somerset, TA20 2GB, UK

Signed: *M Coles* Date: 04<sup>th</sup> May 2022

DEC-056 V3.1

This Machine Has Been Packed  
With The Following

Brush / Pad

Floor Tool

Charging Lead

Fuse Pack

Signed

Distributed by:

# Numatic

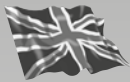

Numatic International Limited.  
Chard, Somerset TA20 2GB ENGLAND  
Tel: 01460 68600 [www.numatic.co.uk](http://www.numatic.co.uk)

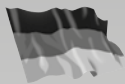

Numatic International GmbH. Fränkische Straße 15–19  
D-30455 Hannover, DEUTSCHLAND  
Tel: 05 11 98 42 16 0 [www.numatic.de](http://www.numatic.de)

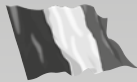

Numatic International SAS. 13 / 17 rue du Valengelier  
EAE La Tuilerie, 77500 CHELLES, FRANCE  
Tel: 01 64 72 61 61 [www.numatic.fr](http://www.numatic.fr)

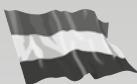

Numatic International BV, Vennootsweg 15  
2404 CG, Alphen aan den Rijn, Nederland  
Tel: 0172 467 999 [www.numatic.nl](http://www.numatic.nl)

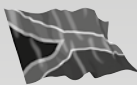

Numatic International (Pty.) Ltd.  
16th & Pharmaceutical Roads, Midrand, Gauteng,  
SOUTH AFRICA 1685  
Tel: 0861 686 284 [www.numatic.co.za](http://www.numatic.co.za)



Numatic International Schweiz AG.  
Sihlbruggstrasse 3A, 6340 Baar. SCHWEIZ  
Tel: 0041 (0) 41 76 80 76 - 0 [www.numatic.ch](http://www.numatic.ch)



Numatic International ULDA. Rua da Boa Viagem, 177  
4470.210 Maia. PORTUGAL  
Tel: +351 220 047 700 [www.numatic.pt](http://www.numatic.pt)



Numatic International SLU. C/ La Forja, 41, 08840 Viladecans  
(Barcelona), Spain  
Tel: +34 93 647 22 22 [www.numatic.es](http://www.numatic.es)

This Product has been comprehensively inspected and checked during every stage of its manufacture.  
Including an in-depth electrical safety and functionality test.

Specification subject to change without prior notice  
[numatic.com](http://numatic.com) © Numatic International Limited

909024 07/22 (A08)